



TEAMCENTER

2D Image Management on Rich Client

Teamcenter 2412

Unpublished work. © 2025 Siemens

This Documentation contains trade secrets or otherwise confidential information owned by Siemens Industry Software Inc. or its affiliates (collectively, "Siemens"), or its licensors. Access to and use of this Documentation is strictly limited as set forth in Customer's applicable agreement(s) with Siemens. This Documentation may not be copied, distributed, or otherwise disclosed by Customer without the express written permission of Siemens, and may not be used in any way not expressly authorized by Siemens.

This Documentation is for information and instruction purposes. Siemens reserves the right to make changes in specifications and other information contained in this Documentation without prior notice, and the reader should, in all cases, consult Siemens to determine whether any changes have been made.

No representation or other affirmation of fact contained in this Documentation shall be deemed to be a warranty or give rise to any liability of Siemens whatsoever.

If you have a signed license agreement with Siemens for the product with which this Documentation will be used, your use of this Documentation is subject to the scope of license and the software protection and security provisions of that agreement. If you do not have such a signed license agreement, your use is subject to the Siemens Universal Customer Agreement, which may be viewed at <https://www.sw.siemens.com/en-US/sw-terms/base/uca/>, as supplemented by the product specific terms which may be viewed at <https://www.sw.siemens.com/en-US/sw-terms/supplements/>.

SIEMENS MAKES NO WARRANTY OF ANY KIND WITH REGARD TO THIS DOCUMENTATION INCLUDING, BUT NOT LIMITED TO, THE IMPLIED WARRANTIES OF MERCHANTABILITY, FITNESS FOR A PARTICULAR PURPOSE, AND NON-INFRINGEMENT OF INTELLECTUAL PROPERTY. SIEMENS SHALL NOT BE LIABLE FOR ANY DIRECT, INDIRECT, INCIDENTAL, CONSEQUENTIAL OR PUNITIVE DAMAGES, LOST DATA OR PROFITS, EVEN IF SUCH DAMAGES WERE FORESEEABLE, ARISING OUT OF OR RELATED TO THIS DOCUMENTATION OR THE INFORMATION CONTAINED IN IT, EVEN IF SIEMENS HAS BEEN ADVISED OF THE POSSIBILITY OF SUCH DAMAGES.

TRADEMARKS: The trademarks, logos, and service marks (collectively, "Marks") used herein are the property of Siemens or other parties. No one is permitted to use these Marks without the prior written consent of Siemens or the owner of the Marks, as applicable. The use herein of third party Marks is not an attempt to indicate Siemens as a source of a product, but is intended to indicate a product from, or associated with, a particular third party. A list of Siemens' Marks may be viewed at: www.plm.automation.siemens.com/global/en/legal/trademarks.html. The registered trademark Linux® is used pursuant to a sublicense from LMI, the exclusive licensee of Linus Torvalds, owner of the mark on a world-wide basis.

About Siemens Digital Industries Software

Siemens Digital Industries Software is a global leader in the growing field of product lifecycle management (PLM), manufacturing operations management (MOM), and electronic design automation (EDA) software, hardware, and services. Siemens works with more than 100,000 customers, leading the digitalization of their planning and manufacturing processes. At Siemens Digital Industries Software, we blur the boundaries between industry domains by integrating the virtual and physical, hardware and software, design and manufacturing worlds. With the rapid pace of innovation, digitalization is no longer tomorrow's idea. We take what the future promises tomorrow and make it real for our customers today. Where today meets tomorrow. Our culture encourages creativity, welcomes fresh thinking and focuses on growth, so our people, our business, and our customers can achieve their full potential.

Support Center: support.sw.siemens.com

Send Feedback on Documentation: support.sw.siemens.com/doc_feedback_form

Contents

Overview of working with 2D images 1-1

Types of 2D files you can open 2-1

Viewing 2D images

| | |
|---|------|
| Overview of viewing 2D images | 3-1 |
| Change your 2D image view | 3-1 |
| View the properties of 2D images | 3-3 |
| Choose how you want to open 2D files | 3-4 |
| Set preferences for viewing 2D images | 3-17 |
| Use multi-touch gestures to view 2D images | 3-20 |
| Use keyboard shortcuts to modify how you view 2D images | 3-20 |
| System administrator reference for configuring default 2D viewing preferences | 3-21 |
| Overview of system administrator reference for configuring default 2D viewing preferences | 3-21 |
| How to change 2D default viewing preferences | 3-21 |

Working with 2D layers

| | |
|---|-----|
| Overview of working with 2D layers | 4-1 |
| Create a new 2D layer | 4-2 |
| Insert a 2D layer | 4-3 |
| Rename 2D layers | 4-3 |
| Delete a 2D layer | 4-4 |
| Save 2D layers | 4-4 |
| Export 2D layers | 4-5 |
| Expand and collapse 2D layers | 4-5 |
| Turn all 2D layers on or off | 4-6 |
| Search for 2D layers | 4-6 |

Working with 2D snapshots

| | |
|--|-----|
| Overview of working with 2D snapshots | 5-1 |
| Add a 2D snapshot | 5-1 |
| Insert a 2D snapshot | 5-1 |
| Replace one 2D snapshot with another | 5-2 |
| Add a name to the 2D snapshot | 5-2 |
| Rearrange 2D snapshots | 5-2 |
| Delete 2D snapshots | 5-2 |
| Display an existing 2D snapshot | 5-3 |

Marking up 2D images

| | |
|--|------|
| Overview of creating 2D markups | 6-1 |
| Add 2D markups | 6-1 |
| Create 2D group markups | 6-4 |
| Select 2D markups | 6-4 |
| Change the appearance of 2D markups | 6-5 |
| Delete 2D markups | 6-6 |
| Set 2D markup preferences | 6-6 |
| Change how existing 2D markups are displayed | 6-10 |
| Using 2D markers | 6-10 |
| Introduction to rubber stamps | 6-13 |
| What are rubber stamps? | 6-13 |
| Create a new rubber stamp | 6-14 |
| Example of a rubber stamp text file | 6-15 |

Working with 2D GD&T markups

| | |
|---|------|
| Overview of working with 2D GD&T markups | 7-1 |
| Open the GD&T annotation editor | 7-1 |
| Create GD&T feature control frames | 7-2 |
| Create GD&T notes | 7-5 |
| Create GD&T datums | 7-7 |
| Create GD&T tolerances | 7-8 |
| Create a GD&T markup stack | 7-9 |
| Edit GD&T markups | 7-10 |
| Change GD&T markup preferences and properties | 7-10 |

Measuring 2D images

| | |
|---|-----|
| Overview of measuring 2D images | 8-1 |
| Calibrate the 2D measurement scale | 8-2 |
| Measure 2D objects | 8-3 |
| Create complex linear measurements | 8-6 |
| Understanding vector and raster measurement differences | 8-7 |
| Configure preferences for measuring 2D objects | 8-8 |

Comparing 2D layers

| | |
|---|-----|
| Overview of comparing 2D layers | 9-1 |
| Configure preferences for comparing 2D layers | 9-1 |
| Create 2D comparison layers | 9-2 |

Adjusting 2D layers

| | |
|-----------------------------------|------|
| Overview of adjusting 2D layers | 10-1 |
| Align 2D vector and raster points | 10-1 |
| Move, zoom, and rotate 2D layers | 10-4 |

Working with PDF documents

| | |
|--|------|
| Accessing PDF documents using different operating systems | 11-1 |
| Viewing PDF documents with attached JT files | 11-1 |
| Display contents of PDF sticky notes | 11-1 |
| Searching PDF documents in Windows | 11-2 |
| About searching PDF documents | 11-2 |
| Change the text highlight color when searching PDF documents | 11-3 |
| Find text strings in PDF documents | 11-3 |



1. Overview of working with 2D images

When you open a 2D image file, an image of the data is displayed in the Viewing window. Detailed data structure is also displayed in the **Assembly** view. The displayed data can vary, since it is dependent on the file format that you have opened.

Use viewing options to modify how the image appears in the Viewing window. These viewing options include tasks such as rotating the image, panning the image, and zooming in or out of the image details. Once the image is opened in the Viewing window, you can add markups, measure distances, and compare different versions of the images, among other 2D image viewing options.

You can also view and work with PDF documents.

2. Types of 2D files you can open

With Teamcenter lifecycle visualization you can open 3D models and 2D images. When you open a 3D model, it opens in a new 3D Viewing window. When you open a 2D image, it opens in a new 2D Viewing window.

You can view and manipulate nearly 50 different types of 2D images. The following list displays examples that represent broad file types:

- Vector file types, for example HPGL or DWF.

Vector images are composed of mathematical lines and curves. The quality of the image does not decrease as you increase viewing magnification.

- Raster file types, for example TIFF or JPEG.

Raster images are composed of thousands of individual pixels. Their image quality decreases as you increase viewing magnification.

- Documentation file types, for example PDF or MSWord.

This group consists of documentation files that combine vector and raster data, for example Adobe Illustration.

When you want to convert a Microsoft Office file and open it in the Viewer, make sure you install Microsoft Office. Microsoft Office files are viewed as PDFs in the Viewer.

Consider the following special instances about opening 2D files:

- Some CAD drawings can be opened as either a 2D image or as a 3D model.
- Many 2D images are structured with data on just one page. There are some 2D files that are structured with multiple sheets, or pages, or layers. You can navigate to individual layers and, for some file types, you can turn layers on or off.



3. Viewing 2D images





Overview of viewing 2D images









When you open a 2D image file, information about the file is displayed in the Viewing window and in the **Assembly** view. The information that is displayed varies depending on the file format you open. Even before opening a 2D image, you can modify viewing preferences and choose how you want to open 2D files. Once the image file is opened, you can manipulate its view, for example by rotating or flipping the image to improve how you work with it.

Change your 2D image view

Do any of the following:

| To | Do this |
|---|---|
| Fit the entire image to the Viewing window. | <p>Do one of the following:</p> <ul style="list-style-type: none">• Right-click in the Viewing window, and choose Fit All.• On the 2D Viewing toolbar, click Fit All . <p>The image zooms proportionally so it fits into and is centered in the Viewing window.</p> |
| Return to base view. | <p>Do one of the following:</p> <ul style="list-style-type: none">• Right-click in the Viewing window, and choose Base View.• On the 2D Viewing toolbar, click Base View . <div style="border: 1px solid black; padding: 5px;"><p>Note:</p><p>The base view of the 2D image is the original document that is opened in the Viewing window. Returning to this view after image manipulation (zooming, panning, and so forth) may be necessary for continued manipulation of the original image. If you add markups to the image,</p></div> |

| To | Do this |
|--|--|
| | <div style="border: 1px solid black; padding: 5px;"> <p>they are associated with the original base view and will be displayed.</p> </div> |
| Zoom a portion of the image to fit the Viewing window. | <ol style="list-style-type: none"> Do one of the following: <ul style="list-style-type: none"> Right-click in the Viewing window, and choose Zoom Area. On the 2D Viewing toolbar, click Zoom Area . Click a point in the Viewing window and drag the cursor to enclose a portion of the image. The selected portion fills the Viewing window. |
| Center a point of your image. | <ol style="list-style-type: none"> Do one of the following: <ul style="list-style-type: none"> Right-click in the Viewing window, and choose Seek. On the 2D Viewing toolbar, click Seek . Click a point in the Viewing window and the image is centered on that point. |
| Pan interactively. | <ol style="list-style-type: none"> Do one of the following: <ul style="list-style-type: none"> Right-click in the Viewing window, and choose Pan. On the 2D Viewing toolbar, click Pan . In the Viewing window, click and drag to pan your view. |
| Zoom interactively. | <ol style="list-style-type: none"> Do one of the following: <ul style="list-style-type: none"> Right-click in the Viewing window, and choose Zoom. On the 2D Viewing toolbar, click Zoom . |

| To | Do this |
|---|--|
| | <p>2. Do one of the following:</p> <ul style="list-style-type: none"> • In the Viewing window, click and drag up and down to zoom in and out. • Roll the mouse wheel forward and back to zoom in and out. <div style="border: 1px solid black; padding: 5px; margin-top: 10px;"> <p>Note:</p> <p>To reverse the behavior, select the Flip mouse direction to zoom check box in View Preferences dialog box.</p> </div> |
| Rotate 90 degrees counterclockwise. | On the 2D Viewing toolbar, click Rotate Counterclockwise  . |
| Rotate 90 degrees clockwise. | On the 2D Viewing toolbar, click Rotate Clockwise  . |
| Zoom in or out incrementally. | On the 2D Viewing toolbar, click Zoom In  or Zoom Out  . |
| Move to the first or last page in a multipage image. | On the 2D Multipage toolbar, click First Page  or Last Page  . |
| Move to the previous or next page in a multipage image. | On the 2D Multipage toolbar, click Previous Page  or Next Page  . |
| Move to a specific page in a multipage image. | On the 2D Multipage toolbar, click Go To Page  . |

View the properties of 2D images

1. Open a 2D image file.
2. Do one of the following:
 - Right-click in the Viewing window, and choose **Properties**.
 - Choose **File**→**Properties**.
3. View file information on the pages of the **Properties** dialog box.

| Choose this tab | To view these properties |
|-----------------|---|
| Layer | Layer (or File) name Author Date created Date last modified Location File Type |
| Image | Dimensions Depth Resolution Density Pens Used (for plotter files) |
| MetaData | Other information that may be attached to the image file. |
| Fonts | <p>(2D vector files only) Font names embedded in the file. If a named font is not present on the system, the substituted font appears in the Font Substitution column.</p> <p>To specify a font to substitute for an embedded font name, in the row for the embedded font name, click the Font Substitution column and select an available font.</p> <div style="border: 1px solid black; padding: 5px; margin-top: 10px;"> <p>Note:</p> <p>Font substitutions specified here are applied only temporarily to the file. To specify persistent font substitutions for all 2D vector files, use the 2D Loader Preferences dialog box.</p> </div> |

Choose how you want to open 2D files

| | | | | | |
|------------------------|----------------|--------------------------|-------------|------------|------------|
| File Extensions | Gerber | HPGL | IGES | PDF | |
| CGM | DWG/DXF | Font Substitution | DGN | DFT | EMF |

Pages in the **2D Loader Preferences** dialog box

Note:

Preferences you set **2D Loader Preferences** dialog box are applied when you subsequently open 2D files. Changes to 2D Loader Preferences are not retroactively applied to currently open files.

1. Choose **File**→**Preferences**→**2D Loader**.
2. In the **2D Loader Preferences** dialog box, click the tab for the page containing the options you want to set.

On any page where **Reset** appears, click **Reset** to restore the default loader preferences for the options on that page.

| On this page | Choose this option | To do this |
|------------------------|----------------------|---|
| File Extensions | None | <p>Display a list of supported files types.</p> <p>To add new file extensions, do this:</p> <ol style="list-style-type: none"> Highlight and double-click a File Type from the list. In the Edit File Extensions dialog box, in the Additional Extensions section, type the new extension. Click OK and the new file extension appears in the Additional column. <div data-bbox="743 827 1451 1470" style="border: 1px solid black; padding: 10px;"> <p>Note:</p> <ul style="list-style-type: none"> Use the File Extensions page to add file extensions to a specific default extension. You cannot add file extensions to file formats marked with an asterisk (*). You can add multiple extensions by using comma-separated entries (abc,def,ghi), without periods. You cannot add an existing default file extension to any other file format. <p>The new extension appears in the file extensions list.</p> </div> |
| Gerber | Layer Colors | <p>Change colors assigned to Gerber layers.</p> <div data-bbox="743 1566 1451 1801" style="border: 1px solid black; padding: 10px;"> <p>Note:</p> <p>Eight layer colors are defined. If the file contains more than eight layers, the colors are reused in the order specified. That is, layer one and layer nine are displayed using the same color.</p> </div> |
| | Aperture File | Select the file used to define shapes within the drawing. |

| On this page | Choose this option | To do this |
|-------------------------|---------------------------------------|--|
| HPGL | Use width of 1 Pixel | Display all lines associated with HGPL files as 1 pixel wide. <div data-bbox="743 327 1451 495" style="border: 1px solid black; padding: 5px; margin-top: 10px;"> <p>Note:</p> <p>The application ignores HGPL file or user defined pen widths.</p> </div> |
| | Use embedded | Select line widths set in the HGPL file. <div data-bbox="743 592 1451 1224" style="border: 1px solid black; padding: 5px; margin-top: 10px;"> <p>Note:</p> <ul style="list-style-type: none"> • When Use embedded is selected, the Width option is disabled and user defined pen widths are ignored. • When Use embedded is selected and If not found, use user defined is cleared, pen widths that are used but not defined in the HGPL file will default to a width of 1 pixel. • When Use embedded is selected and If not found, use user defined is selected, you use HGPL defined pen widths if they are found in the file. If HGPL file pen widths are not found, you use user defined pen widths. Only one set of width definitions are used at a time. </div> |
| | Use user defined | Use HGPL pen widths that you have defined. |
| | Use embedded pen colors | Use the embedded commands to control pen colors. <div data-bbox="743 1377 1451 1614" style="border: 1px solid black; padding: 5px; margin-top: 10px;"> <p>Note:</p> <p>Disabling this option enables default pen colors you set using Pen Colors. The first eight pen colors default to colors defined in the HGPL reference guide. Other pen colors default to black.</p> </div> |
| | View pages as document layers | View files with multiple pages as a single page with multiple layers. |
| Use rotate (RO) command | View files containing the RO command. | |

| On this page | Choose this option | To do this |
|--------------|----------------------------------|---|
| | | <p>Note:</p> <ul style="list-style-type: none"> • This HPGL command rotates images 90, 180, or 270 degrees. • The default setting displays the image using the RO command. • The image is not rotate if the RO command does not exist. |
| | Use legacy RTL processing | <p>Display data correctly in legacy Siemens HPGL files.</p> <p>Note:</p> <ul style="list-style-type: none"> • This option is used only when reading legacy export files. • Support for HP-RTL 2D files is limited to files generated by Lifecycle Visualization using Export Image. |
| | Use Line Caps | <p>Select Use Line Caps to correctly display line ends. Clear the feature to display line ends for legacy data.</p> <p>Note:</p> <p>When this preference is cleared, line ends are displayed as rounded lines.</p> |
| | Font | <p>Select one of five fonts for HPGL text.</p> <p>Note:</p> <ul style="list-style-type: none"> • The five supported fonts include Hershey (the default), Arial, Courier New, Hershey Monospace, and Lucida Console. • Choose the font that works best to display text in an HPGL image, for example, to display text in a text box. |

| On this page | Choose this option | To do this |
|--------------|------------------------|---|
| | | <ul style="list-style-type: none"> The True Type Font, Lucida Console, is supported only if it is installed on your computer. |
| | Pen # | Display the HPGL pen number. |
| | Color and Width | <p>Display the HPGL pen color, by RGB code, you selected. You also display the value for the pen line width.</p> <div data-bbox="743 556 1451 882" style="border: 1px solid black; padding: 5px;"> <p>Note:</p> <p>If you select Use Embedded Pen Widths or Set Pen Widths to 1 Pixel, pen width is controlled by the HPGL file and the Width column is disabled.</p> <p>If you select Use Embedded Pen Colors, pen color is controlled by the HPGL file and the Color column is disabled.</p> </div> <ul style="list-style-type: none"> To specify one of 256 colors, do one of the following: <ul style="list-style-type: none"> Highlight a Pen line by clicking it. (Optional) Hold Ctrl for multiple selections, and then double-click. <p>The Pen Definition dialog box appears. Select a color using the drop-down color selection.</p> (Optional) To set the same pen width for any number of pens: <ol style="list-style-type: none"> Select the first pen row. Hold Shift and select the last desired pen row for this list. Continue to hold Shift and then double-click to open the Pen Definition dialog box. Enter the desired pen width for all selected pens in the Update Pen Width section. Click OK. |

| On this page | Choose this option | To do this |
|--------------|---------------------------------------|---|
| | | <p>Note:</p> <p>See note at the bottom of this page.</p> |
| | Inches | <p>Set the reported HPGL file property units to inches.</p> <p>Note:</p> <p>These options are disabled if you have the EAI_HPGL_UNITS environment variable defined in your settings. The default unit for HPGL files is millimeters.</p> |
| | Millimeters | <p>Set the reported HPGL file property units to millimeters.</p> <p>Note:</p> <p>These options are disabled if you have the EAI_HPGL_UNITS environment variable defined in your settings. The default unit for HPGL files is millimeters.</p> |
| IGES | View predefined views as pages | View predefined views associated with the drawing as additional pages. |
| | Specify a View Angle | Specify the viewing angle. |
| | Common Views | <p>Specify a standard view angle.</p> <ol style="list-style-type: none"> Select Specify View Angle. In Common Views choose a standard view from the list. |
| | X | Choose the view angle for the X axis. |
| | Y | Choose the view angle for the Y axis. |
| | Z | Choose the view angle for the Z axis. |
| PDF | Panning and Zooming Resampling | Re-render the PDF as you pan and zoom. |

| On this page | Choose this option | To do this |
|--------------|--|--|
| | | <p>Note:</p> <ul style="list-style-type: none"> For PDFs containing vector graphics, panning and zooming is much faster when this preference is cleared, but image quality is better when this preference is selected. PDF text search is not available when this preference is off. |
| | Black and white pages as mono color | <p>Render black and white PDFs as grayscale.</p> <p>The default setting, which is cleared, generates these PDFs as grayscale. Grayscale output looks better than black and white.</p> |
| | Smooth raster images | Apply smoothing to minimize abrupt changes in images. |
| | Smooth line art | Apply smoothing to remove abrupt angles in lines. |
| | Smooth text | <p>Apply smoothing to remove abrupt angles in text.</p> <p>Note:</p> <p>When you select these preferences you are optimizing PDF output, but the image can be light. If you clear the preferences, the image may be darker and less clear.</p> |
| Text | Font Name | Change the font of the text file. |
| | Font Style | Change the style of the font. |
| | Font Size | Change the size of the font. |
| | Word Wrapping | Specify whether or not to wrap text. |
| | Copy/Paste | Copy and paste text for use in other applications. |
| | Page Number | Display page numbers at the bottom of each page. |
| | Characters Per Line | Choose the number of characters that appear on each line. |
| | Tab Spaces | Define the number of spaces used for each tab. |
| | Title | Display the file name or full path at the top of each page. |

| On this page | Choose this option | To do this |
|----------------|----------------------------------|--|
| | Portrait or Landscape | Change the layout of the image. |
| ME10 | Line Width to Color table | <p>Specify the line width for selected colors.</p> <ol style="list-style-type: none"> Select the Override box for the line color or colors you want to change. Type the line width for the selected color or colors. <div data-bbox="813 611 1451 774" style="border: 1px solid black; padding: 5px;"> <p>Note: The unit value of Line Width corresponds to the unit of measurement of the image.</p> </div> |
| CalComp | Override Pen Widths | <p>Edit CalComp 906/907 pen widths.</p> <p>(Optional) To set the same pen width for any number of pens:</p> <ol style="list-style-type: none"> Select the first pen row. Hold Shift and select the last pen row from the list. Continue to hold Shift and then double-click to open the Pen Definition dialog box. Enter the desired pen width for all selected pens in the Update Pen Width section. Click OK. <div data-bbox="748 1409 1451 1541" style="border: 1px solid black; padding: 5px;"> <p>Note: See the note at the bottom of this page.</p> </div> |
| | Override Pen Colors | <p>Edit CalComp 906/907 pen colors.</p> <div data-bbox="748 1640 1451 1743" style="border: 1px solid black; padding: 5px;"> <p>Note:</p> <ul style="list-style-type: none"> The default for both options is cleared. </div> |

| On this page | Choose this option | To do this |
|--------------|------------------------------|---|
| | | <ul style="list-style-type: none"> Change single values by double-clicking the row. To edit several colors, highlight the entries and then double-click. <p>Note: See the note at the bottom of this page.</p> |
| Raster | Set the Background Threshold | <p>Move the slider towards Black or White to display the best image.</p> <p>Note: A 1–Bit raster file usually represents a facsimile. To generate the best output results, move the slider all the way to the Black or the White edge and then work in from that point until the best image is reproduced.</p> |
| CGM | Background Color Preferences | <p>Specify the background color associated with the CGM file.</p> <p>You can select Use CGM Background Color or Use Default Background Color.</p> <p>Note:</p> <ul style="list-style-type: none"> CGM files may have dark background colors that affect printing results. You can use this command to choose a default background color. You can also change the default background color. Use the Preference command on the View menu to change background colors. |
| | Line Width Scale | <p>Control the thickness of lines drawn for vector data.</p> <p>Note: If you set the value to 100%, the line is not scaled. Values below 100% will draw thinner lines, and values above 100% draw thicker lines. This setting affects lines, polygons, ellipses, and arcs.</p> |

| On this page | Choose this option | To do this |
|----------------|----------------------------------|---|
| | Stroked Font Width | Override how stroked fonts are drawn. <div data-bbox="745 329 1451 705" style="border: 1px solid black; padding: 5px; margin-top: 10px;"> <p>Note:</p> <p>The standard stroked font is 1 pixel width. If you set the value to 0 or leave it blank, you maintain the default value. When you override stroked font widths you are doing so based on the dimensions of the document and not on the size of the text string. If you set the value to a small floating point less than 1, you make the text strings somewhat bolder.</p> </div> |
| DWG/DXF | Display Layouts as Pages | View saved layouts associated with the drawing as additional pages. |
| | Start on Saved Page | Open the last saved view of the file. <div data-bbox="745 894 1451 1098" style="border: 1px solid black; padding: 5px; margin-top: 10px;"> <p>Note:</p> <p>The default behavior is to open the first page of the DWG/DXF file. This setting modifies the default behavior.</p> </div> |
| | Show Missing Fonts Dialog | Show substitute fonts if the DWG/DXF file contains missing SHX fonts. The check box is cleared by default. |
| | Recover DWG Errors | Automatically recover errors in DWG files when loading them into Teamcenter lifecycle visualization. <div data-bbox="745 1373 1451 1612" style="border: 1px solid black; padding: 5px; margin-top: 10px;"> <p>Note:</p> <p>Since some DWG data may be unspecified or out of range, data may not render correctly. If this happens, you can clear Recover DWG Errors and process DWG files without error recovery.</p> </div> |
| | Thaw Frozen Layers | Control the display behavior of DWG frozen layers. <div data-bbox="745 1707 1451 1850" style="border: 1px solid black; padding: 5px; margin-top: 10px;"> <p>Note:</p> <p>If you select Thaw Frozen Layers, the frozen layer is displayed on the layer page and the layer state</p> </div> |

| On this page | Choose this option | To do this |
|--------------|----------------------|--|
| | | <div style="border: 1px solid black; padding: 5px;"> <p>is set to off. If you clear Thaw Frozen Layers, the frozen layer is not displayed on the layer page.</p> </div> |
| | Override Pens | <p>Override the default pen color, the default pen width, or both.</p> <p>After you select Override Pens, double-click the specific pen or pens you want to change. The Pen Definition dialog box appears and then you can select the desired pen color and pen width, or both.</p> |
| | Color | <p>Choose up to seven default pen colors.</p> <div style="border: 1px solid black; padding: 5px; margin-top: 10px;"> <p>Note: See the note at the bottom of this page.</p> </div> |
| | Width | <p>Set the width of displayed lines.</p> <div style="border: 1px solid black; padding: 5px; margin-top: 10px;"> <p>Note: Setting the width to 0 results in the lines being displayed one pixel wide. Widths greater than 0 increase the displayed line width proportional to the size of the document. Your width should correspond to the size of your document.</p> </div> <p>(Optional) To set the same pen width for any number of pens:</p> <ol style="list-style-type: none"> a. Select the first pen row. b. Hold Shift and select the last desired pen row for this list. c. Continue to Shift and then double-click to open the Pen Definition dialog box. d. Enter the desired pen width for all selected pens in the Update Pen Width section. e. Click OK. |

| On this page | Choose this option | To do this | | | | | | | | |
|---|--|---|----|-------------|--|--|---|---------------|---|-------------|
| | | <p>Note:</p> <p>See the note at the bottom of this page.</p> | | | | | | | | |
| | SHX Font Path | Define the location of AutoCAD SHX files. | | | | | | | | |
| | XREF Path | Define the location of externally referenced files. | | | | | | | | |
| | Unitless File Default | <p>Select a unit of measure from the list.</p> <p>Note:</p> <p>Use this option for DWG and DXF files that are unitless. This option does not override an existing unit of measure.</p> | | | | | | | | |
| | OLE Raster Quality | <p>Change the raster quality of rendered OLE data.</p> <p>Select the raster quality from the following:</p> <table border="1" data-bbox="727 991 1468 1451"> <thead> <tr> <th data-bbox="727 991 1256 1047">To</th> <th data-bbox="1256 991 1468 1047">Select this</th> </tr> </thead> <tbody> <tr> <td data-bbox="727 1047 1256 1194">Render your image with speed at a loss of performance.</td> <td data-bbox="1256 1047 1468 1194">Low This setting is the default.</td> </tr> <tr> <td data-bbox="727 1194 1256 1323">Render your image with reduced textual pixilation at the cost of more memory use and longer load times.</td> <td data-bbox="1256 1194 1468 1323">Medium</td> </tr> <tr> <td data-bbox="727 1323 1256 1451">Render your image at the greatest quality supported, at the cost of memory use and long load times.</td> <td data-bbox="1256 1323 1468 1451">High</td> </tr> </tbody> </table> | To | Select this | Render your image with speed at a loss of performance. | Low This setting is the default. | Render your image with reduced textual pixilation at the cost of more memory use and longer load times. | Medium | Render your image at the greatest quality supported, at the cost of memory use and long load times. | High |
| To | Select this | | | | | | | | | |
| Render your image with speed at a loss of performance. | Low This setting is the default. | | | | | | | | | |
| Render your image with reduced textual pixilation at the cost of more memory use and longer load times. | Medium | | | | | | | | | |
| Render your image at the greatest quality supported, at the cost of memory use and long load times. | High | | | | | | | | | |
| Font Substitution | Table on the page | <p>Specify fonts to substitute for fonts that are named in 2D vector files.</p> <p>Tip:</p> <p>View properties for currently open files to see font names and to temporarily substitute fonts.</p> <p>Font substitution applies to 2D vector files with named fonts for embedded text, such as may exist in CGM, DWG/ DWF, HPGL, and ME10 file types. Font substitution does</p> | | | | | | | | |

| On this page | Choose this option | To do this |
|--------------|-------------------------------------|---|
| | | <p>not apply to PDF files or to Office document types such as DOC or XLS.</p> <ol style="list-style-type: none"> In the table, double-click a cell in the Font column. To add a font name cell, click the top of the empty area in the Font column. Enter the name of a font for embedded text. Press Tab. In the Font Substitution column, select a font from the list of available fonts. |
| DGN | Default Font Resource | Define the location of a default font in the event that your requested font is not supported. |
| | Font File Path | Define the location of a directory of fonts you specify. |
| | SHX Font Path | Define the location of the AutoCAD SHX files. |
| | XREF Path | <p>Do one of the following to define the location of externally referenced DGN files:</p> <ul style="list-style-type: none"> Specify the Search Path. Select the Use Automatic File Locate check box to automatically find files. <p>You can set AutoFile Search preferences to specify how Automatic File Locate searches for files.</p> |
| DFT | Use DFT Background Color | Select the DFT background color. |
| | Use Default Background Color | Select the default background color. |

| On this page | Choose this option | To do this |
|--------------|------------------------------|--------------------------------------|
| EMF | Use EMF Background Color | Select the EMF background color. |
| | Use Default Background Color | Select the default background color. |

- 2D files are displayed using the load preferences you specified.

Note:

- To determine which pens are available to adjust in DWG, HPGL, and CalComp files:
 - Right-click anywhere in the Viewing window and choose **Properties** from the shortcut menu.
- For DGN files:
 - This upgrade results in properly displaying DGN coordinates and units for the current file version. However, you will notice viewing issues with markups, session files, and snapshots when you open DGN files saved from earlier versions. For detailed information about resolving these issues, navigate to the [Siemens Support Center](#) site and review the solution titled *Loading DGN Files with markups from prior releases*.

Set preferences for viewing 2D images

- Open a 2D image file.
- Right-click the Viewing window, and choose **Preferences**.
- In the **View Preferences** dialog box set any of the following options:

| Use this option | To |
|--------------------------------------|---|
| Show border | Display or hide a border around your image. |
| Flip mouse direction for zoom | Specify how you use the mouse to zoom in the Viewing window. <div style="border: 1px solid black; padding: 5px; margin-top: 10px;"> <p>Note:</p> <p>The default behavior for Zoom  is to zoom out by dragging <i>up</i> and zoom in by dragging <i>down</i>. You can reverse this behavior by selecting this option. The option also</p> </div> |

| Use this option | To |
|---|---|
| | <p>reverses the direction you roll the mouse wheel to zoom in or out.</p> <p>This option is set for viewing all models and images. That is, if you specify the default behavior or the reverse behavior for zooming, the option is automatically set for viewing all 2D, 3D, and ECAD data.</p> |
| View base layer in monochrome | Change the colors on your image for better printing on a black and white printer. |
| View black and white images in grayscale | Give better definition to some black and white images by displaying them in shades of gray. |
| Show dashed lines variable length | <p>Maintain a dashed line appearance when zooming in or out of a view.</p> <div data-bbox="618 808 1451 1010" style="border: 1px solid black; padding: 5px;"> <p>Note:</p> <p>Static and variable lines have advantages and disadvantages. You should test which setting works best for the view you want displayed.</p> </div> |
| Enable hotspot highlighting | <p>Activate highlighting WebCGM hotspots.</p> <div data-bbox="618 1104 1451 1346" style="border: 1px solid black; padding: 5px;"> <p>Note:</p> <ul style="list-style-type: none"> • By default, this option is unavailable. • This option is also unavailable if the CGM file does not contain hotspots. </div> |
| Background Color | Change the color of the background. Choose a color from the color list. |
| Feedback Color | Change the color that 2D markups appear in as they are being drawn. Choose a color from the color list. |
| Initial View Rotation | <p>Display images at a specified degree of rotation. Choose from the following:</p> <ul style="list-style-type: none"> • No Rotation • 90 Degrees CW • 90 Degrees CCW |

| Use this option | To |
|--------------------------|--|
| | <ul style="list-style-type: none"> • 180 Degrees <p>By default, images are not rotated.</p> |
| Initial View Mode | <p>Specify your default view mode. Choose from the following:</p> <ul style="list-style-type: none"> • Browse • Zoom Area • Seek • Pan • Zoom <p>The default view mode is Pan.</p> |
| Reported Width | <p>Query the operating system to get the screen width of your display.</p> <div style="border: 1px solid black; padding: 10px; margin-top: 10px;"> <p>Note:</p> <p>The value returned by the operating system is not always accurate enough for precise scaled zooming. Use the displayed value as a guide or indicator.</p> </div> |
| Measured Width | <p>Enable precise screen width by manually measuring the width of the CRT screen using a ruler. This is a side-to-side measurement, in centimeters.</p> <div style="border: 1px solid black; padding: 10px; margin-top: 10px;"> <p>Note:</p> <ul style="list-style-type: none"> • This action is known as calibrating the screen width and when you use it you can zoom to a 1:1 scale of an entity. • Use the 2D Measurement options to calibrate and measure lines and other elements of the 2D image. • Set the Zoom drawing area to be consistent with your measurement values. </div> |

4. Click **Apply**.

2D image files are displayed using the view preferences you have specified.

Use multi-touch gestures to view 2D images

Teamcenter lifecycle visualization supports multi-touch gestures on gesture-enabled hardware.

- To perform a left mouse click for selection, tap the screen with a single finger and release.
- To perform a left mouse click for rotation, tap the screen with a single finger and drag.
- To perform a right mouse click to bring up the context menu, tap the screen with a single finger and hold.
- To zoom in or out, tap the screen with two fingers and move the fingers apart or toward each other.

Use keyboard shortcuts to modify how you view 2D images

Do one or more of the following:

| To | Type this key |
|--|-------------------|
| Move to the previous page. | Page Up |
| Move to the next page. | Page Down |
| Move to the first page. | Home |
| Move to the last page. | End |
| Rotate the image 90 degrees clockwise. | r |
| Rotate the image 90 degrees counterclockwise. | R |
| Search PDF documents for specific text strings. | s |
| Move the image incrementally in the direction of the arrow. <div style="border: 1px solid black; padding: 5px; margin: 5px 0;"> <p>Note: If you selected a markup, you move the markup in the direction of the arrows.</p> </div> | Arrow keys |
| Fit all data inside and outside the bounding box. | F |
| View data only contained inside the bounding box. | f |
| Zoom in. | + |

| To | Type this key |
|------------------------|---------------|
| Zoom out. | - |
| Stop full screen view. | Esc |

System administrator reference for configuring default 2D viewing preferences

Overview of system administrator reference for configuring default 2D viewing preferences

As system administrator, you can modify various default 2D viewing preferences such as CGM and DWG preferences. Your changes will affect the default behavior of working with 2D images. Default preferences are set values that appear when various viewing dialog boxes are opened.

You can configure the following selected 2D loader preference default values:

- Selected 2D viewer preferences default values.
- Selected file extension add-ons – that is, you modify file extensions displayed by the application. Typically, these extensions are specific to your work group.

How to change 2D default viewing preferences

1. Navigate to *Initialization.xml*, which is saved in the */etc* subfolder of the Teamcenter lifecycle visualization installation directory.

Example:

```
C:\Program Files\Siemens\Teamcenter<release_version>\Visualization\etc
```

2. Use a text editor to open, review, and change the values associated with this XML file. Once the changes are made, save the modified *Initialization.xml*.

Tip:

For each section that you configure, be sure to configure the `OverWrite` preference to "Yes" if the current value is set to "No".

Here is sample section of an *Initialization.xml* that shows default 2D viewing options and their values.

```
<Section_2D>
  <LoaderPreferences>
```

```

<CGM>
  <!-- OverWriteCGMPreferences: "yes" "no" -->
  <OverWriteCGMPreferences state="yes" />
  <!-- UseCGMBackgroundColor: "yes" "no" -->
  <UseCGMBackgroundColor state="yes" />
  <!-- LineWidthUpperRange: scale % Options: 100 to 1000 -->
  <LineWidthUpperRange scale="200" />
  <!-- LineWidth: scale % Options: 1 to LineWidthUpperRange -->
  <LineWidth scale="100" />
  <!-- StrokedFontWidth: Options: 0.0 to 10.0 -->
  <StrokedFontWidth value="0.0" />
  <!-- PDFOutputDPI: Options: 200 to 1000 -->
  <PDFOutputDPI value="200" />
</CGM>
<DWG>
  <!-- OverWriteDWGPreferences: "yes" "no" -->
  <OverWriteDWGPreferences state="no" />
  <!-- RecoverDWG: "yes" "no" -->
  <RecoverDWG state="yes" />
  <!-- ThawDWG: "yes" "no" -->
  <ThawDWG state="yes" />
</DWG>
<OVL>
  <!-- OverWriteOVLPreferences: "yes" "no" -->
  <OverWriteOVLPreferences state="yes" />
  <!-- TextAttributes: -->
  <!-- TextAttributes: restricted_text = turning on forces text to
be contained
within a
          bounding box calculated from OVL text information.-->
  <!-- TextAttributes: extra_spacing = ammount to add to spaces
between characters
-->
  <TextAttributes restricted_text="no" extra_spacing="0.1" />
  <!-- Layer Color: to override the color of a OVL layer, turn on
and set RGB
value-->
  <LayerColor override="no" red="0xFF" green="0x00" blue="0x00" />
</OVL>
<IDW>
  <!-- OverWriteIDWPreferences: "yes" "no" -->
  <OverWriteIDWPreferences state="yes" />
  <!-- RasterOnAlpha: "yes" "no" -->
  <RasterOnAlpha state="yes" />
</IDW>
<DWF>
  <!-- OverWriteDWFPreferences: "yes" "no" -->
  <OverWriteDWFPreferences state="yes" />
  <!-- RasterOnAlpha: "yes" "no" -->

```

```

    <RasterOnAlpha state="no" />
</DWF>
<PDF>
  <!-- OverwritePDFPreferences: "yes" "no" -->
  <OverwritePDFPreferences state="yes" />
  <!-- Resample: "yes" "no" -->
  <Resample state="yes" />
  <!-- AllowMonoColor: "yes" "no" -->
  <AllowMonoColor state="no" />
  <!-- SmoothImage: "yes" "no" -->
  <SmoothImage state="yes" />
  <!-- SmoothLine: "yes" "no" -->
  <SmoothLine state="yes" />
  <!-- SmoothText: "yes" "no" -->
  <SmoothText state="yes" />
  <!-- ScaleFactor: "Options: 1.0 to 5.0" -->
  <ScaleFactor state="2.0" />
</PDF>
</LoaderPreferences>
<Vis2D>
  <!-- OverWriteVis2DPreferences: "yes" "no" -->
  <OverWriteVis2DPreferences state="yes" />
  <!-- ExportImage TiffCompression: Options: "none", "zip", "packbits"
-->
  <!-- ExportImage JpegQuality: Options: 1 to 100 -->
  <ExportImage TiffCompression="Packbits" JpegQuality="98" />
</Vis2D>
<ViewPreferences>
  <!-- OverWriteViewPreferences: "yes" "no" -->
  <OverWriteViewPreferences state="no" />
  <!-- ShowBorder: "yes" "no" -->
  <ShowBorder state="no" />
  <BackgroundColor red="0xC0" green="0xC0" blue="0xC0" />
  <FeedbackColor red="0xFF" green="0x00" blue="0xFF" />
  <!-- FlipMouseDirection: "yes" "no" -->
  <FlipMouseDirection state="no" />
  <!-- LineFontStyle: Fonted Lines = "yes" "no" -->
  <LineFontStyle state="no" />
  <!-- RenderQuality 1=LOW 2=MEDIUM (default) 3=HIGH (GreyScale)
-->
  <RenderQuality value="2" />
  <!-- MonoColor: "yes" "no" -->
  <MonoColor state="no" />
  <!-- ViewMode 0=Browse 1=Zoom Area 2=Seek 3=Pan(default) 4=Zoom
-->
  <ViewMode value="3" />
  <!-- RotationMode 0=No Rotation (default) 1=90 Deg CW 2= 90 Deg
CCW 3=180
deg -->

```

```

    <RotationMode value="0" />
    <!-- HotSpotEnable: "yes" "no" -->
    <HotSpotEnable state="no" />
</ViewPreferences>
<FileExtensions>
    <!-- Define additional file extensions using a comma separated list
i.e.,
value = "aaa,bbb"
    Any duplicate entries with either previous additional
extensions or default
extensions
        will cause all values for that extension to be discarded until
duplication is
corrected. -->
    <OverWriteExternsionPreferences state="no" />
    <Extension id ="907" value="" />
    <Extension id ="Adobe Illustrator" value="" />
    <Extension id ="Ascii" value="" />
    <Extension id ="Automation" value="" />
    <Extension id ="Bitmap" value="" />
    <Extension id ="C4" value="" />
    <Extension id ="DGN" value="" />
    <Extension id ="DWF" value="" />
    <Extension id ="EMF" value="" />
    <Extension id ="ETF" value="" />
    <Extension id ="Gerber" value="" />
    <Extension id ="GIF" value="" />
    <Extension id ="HPGL" value="" />
    <Extension id ="IGES" value="" />
    <Extension id ="Inventor" value="" />
    <Extension id ="JPEG" value="" />
    <Extension id ="JPEG 2000" value="" />
    <Extension id ="ME10" value="" />
    <Extension id ="MILR" value="" />
    <Extension id ="MPC" value="" />
    <Extension id ="OVL" value="" />
    <Extension id ="PDF" value="" />
    <Extension id ="PICT" value="" />
    <Extension id ="PNG" value="" />
    <Extension id ="SolidEdge" value="" />
    <Extension id ="Targa" value="" />
    <Extension id ="TIFF" value="" />
    <Extension id ="Zip" value="" />
</FileExtensions>
</Section_2D>

```

4. Working with 2D layers

Overview of working with 2D layers

When you open a 2D image, the file structure details appear in the **Assembly** view and the image appears on the Viewing window. The file structure is reflected in a hierarchical outline. The file details are displayed depending on the file format you open.

When you add structure to the original 2D image, in many instances you are also adding a layer to the structure. The layer is named **Markup Layers**. Markup layers contain a variety of data, including, for example:

- Text or graphic markups.
- Geometric Dimensioning and Tolerancing (GD&T) markups.
- Compatible 2D file data that is inserted into the base file.

Visual references in the **Assembly** view indicate the current visibility state of the 2D image or markup layers.

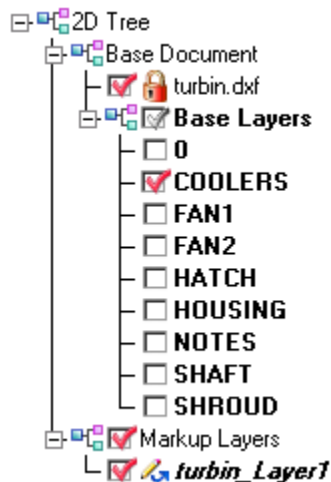

| This state | Indicates |
|------------|--|
| Padlock | The image file or layer is read-only and cannot be modified. |

| This state | Indicates |
|--|---|
| | <div style="border: 1px solid black; padding: 5px;"> <p>Note:</p> <p>In the Assembly view, a 2D image appears listed in a Base Document node. The base document is Read only, as indicated by a padlock icon.</p> </div> |
| <input type="checkbox"/> Blank check box | The layer is hidden. |
| <input checked="" type="checkbox"/> Red check mark | The layer is visible. |
|  <i>turbin_Layer1</i> Pen and arrow and italicized name | The layer was modified. You can save the markup layer to save your changes. |
| Bold font style | One of the following: <ul style="list-style-type: none"> • The active page of a multiple page file. • The original visibility state of XREF layers. • The active markup layer of the open image. |
| <input checked="" type="checkbox"/> Gray check mark | The layer is partially visible. |

Create a new 2D layer

On the **2D Markup** toolbar, click **New Layer** .

-or-

In the **Assembly** view, highlight **Markup Layers** and right-click, then choose **New Layer**.

The new layer is unmanaged until you save it.

Note:

- When you create or edit a 2D layer, a pen and arrow icon  appears before the name of the layer in the **Markup Layers** list until you save the layer. When you save the layer, the icon disappears.
- A new markup layer is automatically created if you add a markup to the base layer using one of the markup tools.

- Sometimes you will want to generate a new layer and then add another markup to this layer. For example, you create a symbol markup and the layer is created automatically. Then, you want to add text about this symbol markup, but you want that text on another layer. For the separate text markup, use **New Layer**.

Insert a 2D layer

1. (If **Markup Layers** list exists) In the **Assembly** view, right-click **Markup Layers**, and choose **Insert Layer**.

-or-

In the **Assembly** view, right-click any node and choose **Insert Layer**.

2. In the **Open** dialog box, browse to and select the file to insert.

The inserted file is listed in **Markup Layers** in the **Assembly** view, and the image appears in the Viewing window.

Note:

- The new layer is unmanaged until you save it.
- You can insert an existing file into the active Viewing window from non-localized locations.

To insert the file where you want it to appear on the layer, use **Inset Image** on the **2D Markup** toolbar.

Once the inserted image is placed on the layer, use the tools on the **2D Adjust** toolbar to manipulate the inserted image. You can move, rotate, and scale the inserted image.

Rename 2D layers

1. In the **Markup Layers** list, right-click the markup layer and select **Rename Layer**.

The name highlights, and an edit box appears around the layer name.

2. Type the new name.
3. To save the new markup layer, right-click the layer and select **Save Selected Layer As**.
4. Enter a new dataset markup layer name in the **New Markup Dataset** dialog box.

- (If you rename a saved markup layer and then right-click and choose **Save Selected Layers**) In the **Question** dialog box, choose to save the layer as a new CGM file (recommended), overwrite the original CGM file, or cancel saving the layer.

Delete a 2D layer

Right-click the markup layer you want to delete and select **Delete Layer**.

Note:

The markup layer is deleted from the current view. When you close the current view, you are given the option to permanently delete the markup layer dataset.

Save 2D layers

- In the **Assembly** view, select the layers you want to save, right-click and choose a save option from the list.

-or-

Choose **File**→**Layers** and select one of the options.

- Choose one of these options:

| Use this option | To save this work |
|--------------------------------|---|
| Save All Layers | All markup layers associated with the base document. |
| Save Selected Layers | Highlighted markup layers associated with the base document. |
| Save Selected Layers As | Highlighted markup layers as a new markup dataset associated with the base document. |
| Save Combined Layers | Highlighted markup layers and merged them into one single layer. <div data-bbox="553 1430 1448 1757" style="border: 1px solid black; padding: 10px; margin-top: 10px;"> <p>Example:</p> <ul style="list-style-type: none"> You have three separate text markup layers contained in one document, named <i>textone</i>, <i>texttwo</i>, and <i>textthree</i>. Highlight all three markup layers and select Save Combined Layers. Name the new markup layer <i>text_markups</i>. </div> |

| Use this option | To save this work |
|-----------------|---|
| | <ul style="list-style-type: none"> All three text markups are displayed when you open the base document and the saved markup layer, <i>text_markups</i>. |

- In the **Save** dialog box, select or type the name of the file you want to save.
- Click **Save**.

(If you chose **Save All Layers**) A new **Save** dialog box appears for each layer.

Note:

When you create or edit a 2D layer, a pen and arrow icon  appears before the name of the layer in the **Markup Layers** list until you save the layer. When you save the layer, the icon disappears.

Export 2D layers

- In the **Assembly** view, highlight the markup layer you want to export.
- Do one of the following:
 - Right-click and choose **Export Layer**.
 - Choose **File**→**Layers**→**Export Layers**.
- In the **Save As** dialog box, accept the defaults or enter a file name and path for the layer you are exporting.
- Click **Save**.

Note:

- When you save a layer, the layer is saved as an element of your dataset.
- When you export a layer, the layer can be saved to any local file system, including a location on your Teamcenter hard drive. You are also prompted to save the changes to the file.

Expand and collapse 2D layers

- Expand and collapse markup layers associated with the top Markup Layer node in one of these ways:
 - Click the **+** or the **-** check box to the left of **Markup Layers**.

- Right-click **Markup Layers** in the **Assembly** view, and choose **Expand** or **Collapse**.

Turn all 2D layers on or off

In the **Assembly** view, turn markup layers on or off by selecting or clearing the red check mark to the left of **Markup Layers** .

If the check box is selected, all markup layers are turned on. If you clear the check box, all markup layers are turned off.

Search for 2D layers

1. Select the top **Markup Layers** node, right-click, and choose **Find**.
2. In **Find what**, type the text string you want to find.
3. (Optional) To find entries that contain the text string as a whole word, select **Match whole word only**.
4. (Optional) To find entries that use the same capitalization as the text string, select **Match case**.
5. Click **Find Next**.

The first entry that contains the text string is selected.

6. To close the **Find** dialog box, click **Cancel**.

5. Working with 2D snapshots

Overview of working with 2D snapshots

Snapshots capture the current state of your view. A snapshot saves view magnification, position, orientation, markup layer visibility, and the current page for multiple page images.

Note:

- Snapshots do not save the layer visibility state of images with multiple image layers.
- The shortcut menu option **Save as a Teamcenter Snapshot** is only available in the Lifecycle Visualization viewer if you are working with data from Teamcenter.

Snapshots appear as thumbnail images in the **Snapshots** view.

You can double-click a snapshot to make the current view match the snapshot.

Snapshot commands are in the **Snapshots** toolbar, in the **Snapshots** menu, and in the shortcut menu that you access by right-clicking inside the **Snapshots** view.

Add a 2D snapshot

1. Manipulate the contents of the Viewing window until you create a view you want to save.
2. Do one of the following:
 - In the **Snapshots** view, right-click and choose **Add**.
 - On the **Snapshots** toolbar, click **Add** .

Insert a 2D snapshot

1. Click the **Snapshots** view to activate Snapshots.
2. In the **Snapshots** view, select a snapshot.
3. Manipulate the image until the Viewing window displays the view of interest.
4. Do one of the following:
 - In the **Snapshots** view, right-click a snapshot and choose **Insert**.

- On the **Snapshots** toolbar, click **Insert** .

The snapshot is inserted in the **Snapshots** view before the previously selected snapshot.

Replace one 2D snapshot with another

1. Click the **Snapshots** view to activate Snapshots.
2. In the **Snapshots** view, select the snapshot to be replaced.
3. Manipulate the view until the Viewing window displays the view you want to save.
4. Do one of the following:
 - Right-click a snapshot and click **Replace**.
 - On the **Snapshots** toolbar, click **Replace** .

The selected snapshot disappears and it is replaced by the new snapshot.

Add a name to the 2D snapshot

1. Click the **Snapshots** view to activate Snapshots.
2. In the **Snapshots** view, right-click a snapshot, and then click **Name**.
3. In the **Snapshot Name** dialog box, in **Name**, type a new name for this snapshot.

The snapshot name is displayed when you hold the cursor on the snapshot.

Rearrange 2D snapshots

1. In the **Snapshots** view, click a snapshot and drag it to another position.
2. To drag multiple snapshots, hold Ctrl as you select the snapshots, and then drag the group to another position.
3. To drag a series of snapshots, hold Shift as you select the first and last snapshots in the series, and then drag the series to another position.

Delete 2D snapshots

1. Click the **Snapshots** view to activate Snapshots.

2. Do one of the following:
 - In the **Snapshots** view, right-click the snapshot and choose **Delete**.
 - In the **Snapshots** view, select the snapshot you want to delete, and then on the **Snapshots** toolbar, click **Delete** .

Display an existing 2D snapshot

1. Click the **Snapshots** view to activate Snapshots.
2. Display an existing snapshot in one of these ways:
 - In the **Snapshots** view, double-click the desired snapshot.
 - Right-click the snapshot and choose **Recapture Image**.

The existing snapshot opens in the Viewing window.

6. Marking up 2D images

Overview of creating 2D markups

Markups are text or graphic elements that you add to the Viewing window. Markups can be text, lines, shapes, marker points, 2D images from other files, rubber stamps, URLs, and measurements. You can group selected markups together and move them as a single entity.

Markups go on markup layers and appear in the Viewing window along with the base image. You can turn markup layers on and off to control the visibility of markups.

You can set markup preferences for line style, color, width, font, style, and size. You can also select markups and edit the same properties.

When you capture or export an image of your Viewing window, the image includes all visible markups.

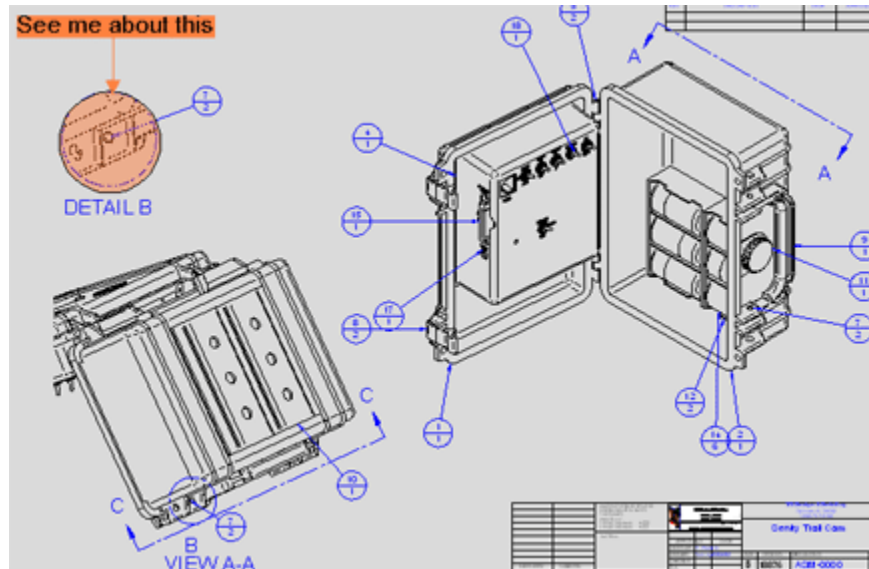











2D markup commands are on the **2D Markup** toolbar and **Markup** menu.



Add 2D markups

1. On the **2D Markup** toolbar, click **Enable Markup** .
2. Do any of the following:

| To | Do this |
|--|--|
| Draw straight lines or freehand lines | <p>a. Choose Line  or Freehand line .</p> <p>b. In the Viewing window, point to the start of the line.</p> <p>c. Click and drag to draw the line.</p> <p>d. Release the mouse button to end the line.</p> <div data-bbox="618 537 1451 701" style="border: 1px solid black; padding: 5px;"> <p>Tip: To draw horizontal or vertical lines, use the Shift key with Line.</p> </div> |
| Draw lines with arrows, or multi-segment lines | <p>a. Choose Leader Line  or Polyline .</p> <p>b. Click to start each segment.</p> <p>c. Double-click to stop.</p> <div data-bbox="618 966 1451 1129" style="border: 1px solid black; padding: 5px;"> <p>Tip: To draw horizontal or vertical line segments, use the Shift key with Leader Line and Polyline.</p> </div> |
| Draw rectangles or ellipses | <p>a. Choose Rectangle  or Ellipse .</p> <p>b. Click and drag to draw.</p> <div data-bbox="618 1318 1451 1453" style="border: 1px solid black; padding: 5px;"> <p>Tip: To draw squares or circles, use the Shift key.</p> </div> |
| Draw non-rectangular closed polygonal shapes | <p>a. Choose Polygon .</p> <p>b. Click points to draw each segment.</p> <p>c. Double-click to stop.</p> |

| To | Do this |
|---|--|
| | <p>Tip:</p> <p>To draw horizontal and vertical line segments, use the Shift key.</p> |
| Add text markups | <ol style="list-style-type: none"> Choose Restricted Text  or Unrestricted Text . Drag a text box for Restricted Text. Select a point for Unrestricted Text. Type the text in the Text Editor. |
| Insert an image file | <ol style="list-style-type: none"> Choose Inset Image . Select a 2D image file to insert Click and drag to specify a rectangular area for the image. |
| Insert a text string from a text file of standard notes | <ol style="list-style-type: none"> Choose Rubber Stamp . Select standard notes from a specified text file. Insert the selected note as a text markup. |
| Place point markers at intersections, midpoints, centers, and endpoints | <ol style="list-style-type: none"> Choose Freehand Marker, Intersection Marker, Midpoint Marker, and Centerpoint Marker. Click points. |

Note:

Use the markers as select points for measurements. The markers improve the accuracy of measuring distances and angles in your 2D images.



Tip:

Use markup **preferences** to specify colors, fill styles, line styles and sizes before you create new markups.

To change appearance of an existing markup, click the markup and then right-click inside the markup bounding area and choose **Properties**.

You can also create new markup layers with **New Layer** .

Create 2D group markups

1. On the **2D Markup** toolbar, click **Enable Markup** .
2. On the **2D Markup** toolbar, click **Select** .
3. Use the Shift or Ctrl key to select several markups, or drag a rectangle around the markups to be grouped.
4. Right-click a markup and choose **Group**.
5. (Optional) To ungroup a markup group, right-click on the group and choose **Ungroup**.

Select 2D markups

1. On the **2D Markup** toolbar, click **Select** .
2. In the **Assembly** view, select the markup layer from the list. Be sure to select the target markup layer so **Select** highlights the correct markup.
3. To select an individual markup, click the markup in the Viewing window.
4. (Optional) Select multiple markups in one of these ways:
 - On the Viewing window, click and drag the cursor, creating a rectangle around markups.
 - On the Viewing window or in the **Assembly** view, hold the Shift or Ctrl key as you click markups.

When selected, one or more markups appear with square green handles at the corner of the bounding box or markups are surrounded by a green border.

Tip:

To deselect the markups, click a blank space in the image.

5. Once the markup is highlighted, you can move the markup by selecting it and moving it to a different location.

- Right-click a highlighted markup and choose an option from the shortcut menu.

Shortcut menu options are enabled or disabled depending on the type of markup you highlighted.

Change the appearance of 2D markups

- Select** a markup.
- Move the markup in one of these ways:

| To move the markup in this way | Do this |
|---------------------------------|---|
| Around the Viewing window | Click the markup and drag it to a new position. |
| To the front (closest to you) | Right-click the markup and choose Bring to Front . |
| To the back (farthest from you) | Right-click the markup and choose Send to Back . |
| Forward (closer to you) | Right-click the markup and choose Bring Forward . |
| Back (farther from you) | Right-click the markup and choose Send Back . |
| Cut or copy and paste | <ol style="list-style-type: none"> Right-click the markup and choose Cut or Copy. Right-click in the Viewing window and choose Paste. <div style="border: 1px solid black; padding: 5px; margin-top: 10px;"> <p>Note:</p> <p>If you paste the 2D markup into the same 2D markup layer, it appears on top of the existing markup. Click the copied 2D markup, and drag it to a new position.</p> </div> |
| Resize | Select the markup and click one of the handles of the bounding box. Drag the handle up, down, left, or right. |
| Rotate | Select the markup and right-click. From the shortcut menu, choose Rotate Clockwise or Rotate Counterclockwise . |

Note:

When you create a new markup, it is placed in the most forward (front) position on the markup layer.

Delete 2D markups

1. **Select the markup** you want to delete.
2. Delete the markup in one of these ways:
 - In the Viewing window, right-click the markup and choose **Delete**.
 - Press the Delete key on your keyboard.

Set 2D markup preferences

1. On the **Markup** toolbar, click **Preferences** .
2. In the **Preferences** dialog box, select any of the following preferences:

| On this tab | Use this option | To do this |
|-------------|-------------------|--|
| Line | Line Style | Specify the style of 2D markup lines. This applies to Line, Polyline, Leader Line, and Freehand Line markups. |
| | Line Color | Specify the color of 2D markup lines. This applies to Line, Polyline, Leader Line, and Freehand Line markups. |
| | Thickness | Specify the thickness of 2D markup lines (0-99). This applies to Line, Polyline, Leader Line, and Freehand Line markups. <div style="border: 1px solid black; padding: 10px; margin-top: 10px;"> <p>Note:</p> <ul style="list-style-type: none"> • Lines with a value of 0 appear one pixel thick but do not scale when you zoom. • Line thickness is in millimeters for all documents, regardless of document unit. </div> |

| On this tab | Use this option | To do this |
|-------------|-----------------------------|--|
| Edge | Edge Style | Specify the style of ellipse, rectangle, and polygon borders. |
| | Edge Color | Specify the color of ellipse, rectangle, and polygon borders. |
| | Thickness | Specify the line thickness of ellipse, rectangle, and polygon borders. <div style="border: 1px solid black; padding: 10px;"> <p>Note:</p> <ul style="list-style-type: none"> • Lines with a value of 0 appear one pixel thick but do not scale when you zoom. • Line thickness is in millimeters for all documents, regardless of document unit. </div> |
| Fill | Fill Style | Specify the style of ellipse, rectangle, polygon, and text boundary fill. |
| | Fill Color | Specify the color of ellipse, rectangle, polygon, and text boundary fill. |
| | (Under Transparency) Enable | Specify a transparent fill color. |
| Text | Font name | Select the font name for your 2D markup. |
| | Font style | Select the font style for your 2D markup. <div style="border: 1px solid black; padding: 10px;"> <p>Note:</p> <p>Available font styles depend on which fonts are installed on the computer.</p> </div> |
| | Font size | Select the font size. |
| | Text Path | Specify the direction for your text. |
| | Color | Select the text color. |
| | Underline | Not available at this time. |
| | Strikeout | Not available at this time. |
| | Window size | Scale text relative to the current window size. With this option, when you add a text markup, its text height is the result of scaling the font size to the current size of the Viewing window. If you add a text markup, resize (or zoom) the Viewing |

| On this tab | Use this option | To do this |
|---------------------|---|---|
| | | window, and then add a second text markup, the text heights are different. |
| | Layer size | <p>Scale text relative to the layer (image) size.</p> <p>With this option, when you add a text markup, its text height is the result of scaling the font size to the overall image size. If you add a text markup, resize (or zoom) the Viewing window, and then add a second text markup, the text heights are the same. This assumes you do not change the size of the layer (image) by adding markups outside the original image limits. If you increase the image size by adding markups outside the original limits, new text markups are scaled relative to the new image size.</p> |
| Leader | Style | From Begin and End , select the line terminator style. |
| | Width | Specify the width of terminators on leader lines. |
| | Length | Specify the length of terminators on leader lines. |
| Rubber Stamp | Notes File | Choose a text file for your rubber stamp. |
| | (Selected Note) Index | Select the markup index number in the text file. |
| | (Selected Note) Title | Display the title for the index number selected. |
| | (Selected Note) Text | Display the text for the index number selected. |
| | Edit | Select the stamp text for editing. |
| | Restrict | <p>Select a restricted Rubber Stamp.</p> <p>When you choose this option, your Rubber Stamp text is contained within a standard text box. You can place the rubber stamp anywhere on the page by moving and resizing the text box.</p> |
| | Display dialog when rubber stamp activated | Display the Rubber Stamp page of the Preferences dialog box when you activate the rubber stamp markup. |
| Marker | Marker Type | Change the style of the marker. |

| On this tab | Use this option | To do this |
|-------------|--|---|
| | | <p>Note:</p> <p>Use markers for detailed measurements.</p> |
| | Marker Size | <p>Change the size of the marker (0-99).</p> <p>Note:</p> <ul style="list-style-type: none"> To ensure the image is displayed correctly, setting the size of the dot marker type has been disabled. If a marker size is zero, it is drawn as a constant 10 pixels but does not scale when you zoom. A marker greater than zero scales when you zoom. <p>Example:</p> <p>If a document is 64 mm by 64 mm, a marker drawn with a size of 1 will take up 1 mm of the document, or 1/64 of its width and height.</p> |
| | Marker Color | Change the color of the marker. |
| | Snap all picks to vectors | Place new markers only on vector points. |
| | Midpoint percentage (from left) | <p>Enter the integer percent to use to calculate the midpoint. (1-100).</p> <p>Note:</p> <p>The default value is 50%, which represents the midpoint of the line segment.</p> |

3. Click **OK**.

Note:

You use markup preferences to specify markup colors, sizes, and styles for new markups. Later, after a markup has been created, you can also change many appearance preferences by using the **properties** option.

Change how existing 2D markups are displayed

1. **Select** an existing markup.
2. Right-click the markup and choose **Properties**.
3. Change the property settings as needed for each markup.

Note:

Examples of markup properties include line and fill styles and colors.

Using 2D markers

Use 2D markers to improve and manage the accuracy of measuring distance between elements associated with your 2D images. There are four types of point markers that can be further modified to better meet your needs.

Use **Markup preferences** to modify the appearance of your point markers, including such elements as the type of marker, its size, and its color.

Freehand Markers

| To place a point here | Set Vector Snap to | Then do this |
|---|--------------------|--|
| The vector point nearest to the pick point. | On | Click on or near a vector point or entity. |
| The point of your cursor. | Off | Click anywhere on the 2D markup layer. |

Intersection Markers

| To place a point here | Select this intersection | Set Vector Snap to | Then do this |
|--|--------------------------|--------------------|--|
| The intersection point of the two lines. | Line-to-Line | On | <ol style="list-style-type: none"> 1. Select a non-vertex point on a line. 2. Select another non-vertex point on a line. |
| The intersection point of the lines created with the points. | Line-to-Line | On | <ol style="list-style-type: none"> 1. Select a vertex point. <p>This represents the beginning of the line.</p> |

| To place a point here | Select this intersection | Set Vector Snap to | Then do this |
|---|--------------------------|--------------------|---|
| | | | <ol style="list-style-type: none"> Select another vertex point of the same line. This represents the end of the line. Select a non-vertex point on a line or entity (shape). |
| The intersection point of the two lines created with the points. | Line-to-Line | On | <ol style="list-style-type: none"> Select a vertex point. Select another vertex point. These points represent the first line. Select a vertex point. Select another vertex point. These two points represent the second line. |
| The intersection of the circle or circular arc and the line, nearest to the last pick point entered. | Circle-to-Line | On | <ol style="list-style-type: none"> Click a point on a circle or circular arc. Click a non-vertex point on a line. |
| The intersection point of the circle or circular arc and the line, nearest to the last pick point entered. | Circle-to-Line | On | <ol style="list-style-type: none"> Click a point on a circle or circular arc. Click a vertex point. This represents the start of a line. Click on another vertex point on a line. This represents the end of a line. |
| The intersection point of the ellipse or elliptical arc and the line, nearest to the last pick point entered. | Ellipse-to-Line | On | <ol style="list-style-type: none"> Click a point on an ellipse or elliptical arc. Click a non-vertex point on a line. |
| The intersection point of the ellipse or elliptical arc and the line, nearest | Ellipse-to-Line | On | <ol style="list-style-type: none"> Click a point on an ellipse or an elliptical arc. |

| To place a point here | Select this intersection | Set Vector Snap to | Then do this |
|---|--------------------------|--------------------|--|
| to the last pick point entered. | | | <ol style="list-style-type: none"> Click a vertex point on a line. This is the start of a line. Click on another vertex point. This is the end of the line. |
| The intersection point of the two lines. | Line-to-Line | Off | <ol style="list-style-type: none"> Click a point anywhere within the 2D markup layer. This defines the first line. Click another point within the 2D markup layer. This represents the second line. Click another point anywhere in the 2D markup layer. Click another point in the 2D markup layer. |
| The intersection point of the two entities, nearest to the last pick point entered. | Circle-to-Circle | On | <ol style="list-style-type: none"> Select a point on a circle or circular arc. Select another point on a circle or circular arc. |
| The intersection point of the two entities, closest to the second pick point. | Circle-to-Ellipse | On | <ol style="list-style-type: none"> Select a point on a circle or circular arc. Select a point on an ellipse or elliptical arc. |
| The intersection of the two entities, closest to the second pick point. | Ellipse-to-Ellipse | On | <ol style="list-style-type: none"> Select a point on an ellipse or elliptical arc. Select another point on an ellipse or elliptical arc. |

Note:

- The software automatically extrapolates lines if necessary to reach a point of intersection.

- A vertex point of a simple line is an endpoint. For a shape or for polylines, the vertex is the point where the segments join.
- A non-vertex point is a point on a line other than those defined above.

Midpoint Markers

| To place a point here | Set Vector Snap to | Then do this |
|------------------------------------|--------------------|--|
| The midpoint on the selected line. | On | Select a non-vertex point on a line. |
| The midpoint on the created line. | Off | <ol style="list-style-type: none"> 1. Click on a point anywhere in the 2D markup layer. 2. Click on another point anywhere in the 2D markup layer. <p>These two points represent a line.</p> |

Note:

The default value for this setting is 50% – the midpoint value. To divide a line or distance differently, for example into fifths, use **marker preferences**.

Centerpoint Markers

| To place a point here | Set Vector Snap to | Then do this |
|--|--------------------|---|
| The center of circle or circular arc. | On | Click on a circle or circular arc entity. |
| The center of the ellipse or elliptical arc. | On | Click on an ellipse or an elliptical arc entity. |
| The center of the approximated circular arc. | Off | <p>Click on three points anywhere on the 2D markup layer.</p> <p>These three points represent a circular arc.</p> |

Introduction to rubber stamps

What are rubber stamps?

A rubber stamp markup is a markup that is composed of text the you create. You can specify the font size and font type for the text message, and you can specify how you want to display the current date and time.

By default, each rubber stamp includes the prepared markup text, an index number, and a name or title.

- The index numbers do not need to be sequential.
- The first line of the rubber stamp begins with a number symbol (#), followed by the identifying number and name of the rubber stamp.
- Text lines that do not begin with a number symbol display as stamp text.
- The percent sign is development code in rubber stamps. To display a percent sign in your text, type %%.

Example:

For example, to create a rubber stamp markup that includes `Reduce this cost by 15%`, in the rubber stamp text file you would type **Reduce this cost by 15%%**.

Create a new rubber stamp

1. In a text editor, create a text file that includes the following elements:

| To | Type this text |
|--|--|
| Specify the rubber stamp index number and title. | <code>#<markup index number> <markup name></code> |
| Specify the font size and type for the rubber stamp. | <code>\char()\font()</code> <div data-bbox="743 1182 1451 1367" style="border: 1px solid black; padding: 5px; margin-top: 10px;"> <p>Example: <code>\char(12)\font(Arial)</code> This is Arial 12 pt text.</p> </div> |
| The text of the rubber stamp. | <code><Markup text></code> |

2. (Optional) On a separate line for each option, use the following syntax for both date and time.

`\Date(<format option>)`

| Use this option | To get this result |
|-----------------|--------------------------|
| <code>%a</code> | Abbreviated weekday name |
| <code>%A</code> | Full weekday name |
| <code>%b</code> | Abbreviated month name |

| Use this option | To get this result |
|-----------------|--|
| %B | Full month name |
| %c | Date and time representation appropriate for the locale |
| %d | Day of the month |
| %H | Military hour |
| %I:%M:%S:%p | Time Hours, Minutes, Seconds, am/pm |
| %j | Day of year as decimal number 001 - 366 |
| %U | Weekday as decimal number 0 - 6; Sunday is 0 |
| %W | Week of year as decimal number 00 - 53, with Monday as first day of week |
| %x | Date for current locale |
| %X | Time for current locale |
| %y | Year without century |
| %Y | Year |
| %m | Month number |
| %z | Time zone name or abbreviation |
| %Z | No characters if time zone is unknown |

3. (Optional) Repeat steps 1 and 2 as many times as necessary.
4. Save the file with a text (.txt) extension.
5. (Optional) Edit a saved rubber stamp or text markup by double-clicking the markup.
6. (Optional) In the **Text** dialog box of a saved rubber stamp markup, enter your changes.

Example of a rubber stamp text file

```
#1 Contact Supervisor to discuss\char(20)\font(Courier New)Technical
problem with this Please contact me as soonas possible to discusstel
555 123 4567#2 Contact ABC Department Supervisor\char(20)\font(Courier
New)Please contact the ABC Dept. Supervisor to discuss asapTel 555
234 5678#300 OK to changeThese changes have been authorizedBy W.W.
SupervisorRef: DOC No. xxxxxxxxPlease see annotationsVerified \Date(%m/%d/
%Y)#100 XYZ specs incorrectNot correct to XYZ 1.2345.6Please refer
to the manualor discuss with your local XYZ.#106 Required Yes or No
AnswerCan I make this change Y / Ntel 555 345 6789
```

Example:

The following process generates the text in #1 above.

- Copy the text above and save to your local file system (as a .txt file).
- From 2D Example files, open *shuttle.dwf*.
- Select the **2D Markup** toolbar and choose **Rubber Stamp** .

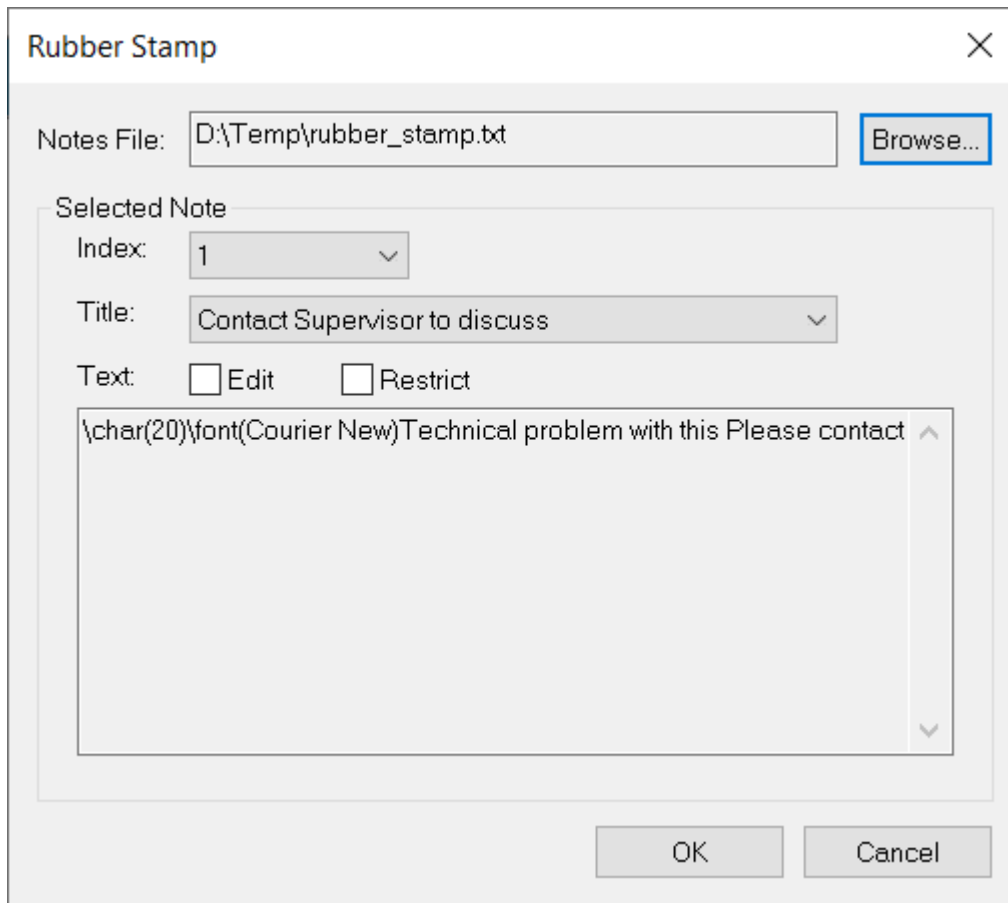

- Click **OK**, and then move your icon to the image location where you want to display the rubber stamp text and click.

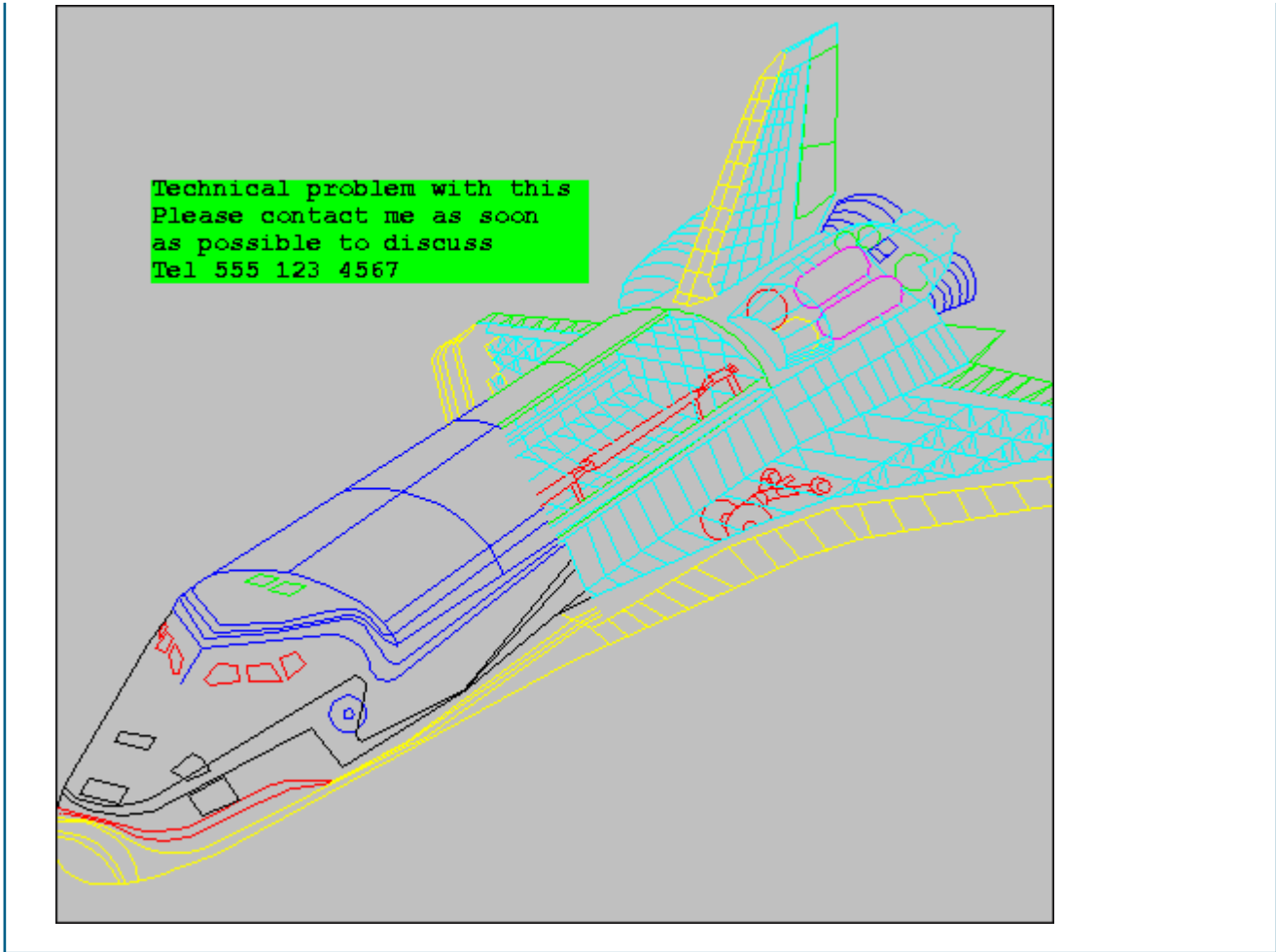

7. Working with 2D GD&T markups

Overview of working with 2D GD&T markups

GD&T markups are text or graphic elements that are included on a markup layer. Using GD&T markups, you add tolerance specifications to your files.

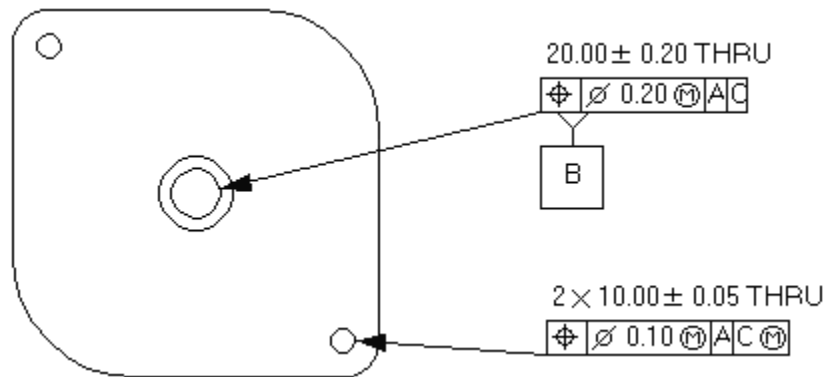

GD&T markups consist of the following:

| GD&T Markup type | Description |
|------------------------|---|
| Feature control frames | |
| Notes | <p>GD&T notes can include the following special symbols:</p> <p> </p> |
| Datums | |
| Tolerances | <p>4 X $\varnothing 3.000 \pm .002$ THRU</p> <p>90.0000 $\pm .0500$</p> <p>$\varnothing 2.0000 \begin{matrix} +.0005 \\ -.0000 \end{matrix}$</p> |

Open the GD&T annotation editor



Use the **GD&T Annotation Editor** dialog box to author feature control frames, notes, datums, and tolerance GD&T markups. The editor displays supported options.

- On the **GD&T Markup** toolbar, select **GD&T Annotation Editor** .

Create GD&T feature control frames













Create GD&T feature control frames that can include geometric tolerance symbols, their values, modifiers, and datum references.

- Do one of the following:



| To | Do this |
|---|--|
| To place the markup anywhere in the view. | On the GD&T Markup toolbar , ensure Stack Mode  is not enabled. |
| To add the markup to a GD&T markup stack. | On the GD&T Markup toolbar , click Stack Mode  . |

- On the **GD&T Markup** toolbar, select **GD&T Annotation Editor** .
- In the **GD&T Annotation Editor** dialog box, on the Feature Control Frame page, select a feature control frame characteristic from the **Characteristic** section.

| Use this symbol | To represent this |
|-----------------|-------------------|
| — | Straightness |

| | |
|---|----------------------|
|  | Flatness |
|  | Circularity |
|  | Cylindricity |
|  | Profile of a line |
|  | Profile of a surface |
|  | Angularity |
|  | Perpendicularity |
|  | Parallelism |
|  | Position |
|  | Concentricity |
|  | Symmetry |
|  | Circular Runout |
|  | Total Runout |

4. In the **Tolerance** section, select a symbol that you want to precede the tolerance value.







| Use this symbol | To represent this |
|---|--------------------|
|  | Diameter |
|  | Spherical Diameter |

5. In the **Tolerance** dialog box, type a value for the tolerance.

Note:



You can use numeric and ASCII values.

6. In the **Tolerance** section, use the drop-down list box to select a modifier that applies to the tolerance.

| Use this symbol | To represent this |
|---|----------------------------------|
|  | MMC - Maximum Material Condition |
|  | LMC - Least Material Condition |
|  | Free State |
|  | Projected Tolerance Zone |
|  | Tangent Plane |
|  | Statistical Tolerance |

You can select several modifiers. Subsequent modifiers are based on your initial modifier selection.

7. (If you have used the **Projected Tolerance Zone** modifier) Type a value in the box that appears below the **Projected Tolerance Zone** modifier.
8. In the **Primary Datum** section:
- Select a datum (**A-D**) from the list.
 - Type one of these datum options:

| Use this symbol | To represent this |
|---|----------------------------------|
|  | MMC - Maximum Material Condition |
|  | LMC - Least Material Condition |

9. (Optional, to create a compound datum) Choose the second **Primary Datum** menu, and select a secondary datum.

Note:

You can create up to six compound datums. After you select a primary datum, menus for a secondary datum appear. If a secondary datum is specified, menus for a tertiary datum appear. The secondary and tertiary datums can be compounded up to six times.

- In the **KPC Symbol** section, type a number that appears inside the KPC symbol.

The KPC symbol displays to the right of the **Feature Control Frame** dialog box.

- (Optional) To define a composite feature control frame, populate the composite tolerance input fields and datum fields to completely define it.

Note:

The characteristic field is limited to a positional or profile tolerance only.

- (Optional) To clear symbols currently entered in the **GD&T Annotation Editor** dialog box, click **Clear All**.
- To manage feature control frame setting, on the Feature Control Frame page of the **GD&T Annotation Editor** dialog box, select one of the following options:



| Click this | To do this |
|-------------------------|---|
| Add to Favorites | Add the current settings to the Favorites combo box (up to 5). |
| Update Favorite | Change the setting of the selected favorite (shown in the combo box). |
| Clear All | Clear your current settings. |

- To insert the markup, click **OK**.
- In the Viewing window, depending on your insertion mode, click any point in the view or select a GD&T markup stack to add to.













Create GD&T notes

Create notes that include GD&T symbols.

- Do one of the following:

| To | Do this |
|---|--|
| To place the markup anywhere in the view. | On the GD&T Markup toolbar , ensure Stack Mode  is not enabled. |
| To add the markup to a GD&T markup stack. | On the GD&T Markup toolbar , click Stack Mode  . |

- On the **GD&T Markup toolbar**, select **GD&T Annotation Editor** .
- Navigate to the Notes page and in the **Text** section, enter your text and choose a symbol from the **Symbols** section (optional).

| Use this symbol | To represent this |
|---|-----------------------|
|  | Countersink |
|  | Counterbore/Spotface |
|  | Depth/Deep |
|  | Conical Taper |
|  | Slope |
|  | Square |
|  | Between |
|  | Plus/Minus |
|  | Degrees |
|  | Diameter |
|  | Spherical Diameter |
|  | Statistical Tolerance |



- (Optional) To set the color of the characters and symbols within a note, click **Text Color** and select a color.
- (Optional) Click **Clear All** to clear the text and symbol entries.
- To insert the markup, click **OK**.

- In the Viewing window, depending on your insertion mode, click any point in the view or select a GD&T markup stack to add to.

Create GD&T datums

Add GD&T datum feature and target symbols to 2D images.

- Do one of the following:



| To | Do this |
|---|--|
| To place the markup anywhere in the view. | On the GD&T Markup toolbar , ensure Stack Mode  is not enabled. |
| To add the markup to a GD&T markup stack. | On the GD&T Markup toolbar , click Stack Mode  . |

- On the **GD&T Markup toolbar**, select **GD&T Annotation Editor** .
- In the Datums page, in the **Datum Type** section, choose **Feature** or **Target**.
- For **Feature**, in the **Datum Identifier** section, type the datum identifier letter that you want to use.

Note:

You can create double letter datums such as AA.

- For **Target**, do the following:
 - In the **Size** section, type a value.
Use both numeric and ASCII characters.
 - In the **Identifier** section, type the identifier and, optionally, select a symbol from the following list:



| Use this symbol | To represent this |
|---|-------------------|
|  | Diameter |
|  | Box |

- (Optional) Use **Clear All** to clear text.



7. To insert the markup, click **OK**.
8. In the Viewing window, depending on your insertion mode, click any point in the view or select a GD&T markup stack to add to.

Create GD&T tolerances

1. Do one of the following:

| To | Do this |
|---|--|
| To place the markup anywhere in the view. | On the GD&T Markup toolbar , ensure Stack Mode  is not enabled. |
| To add the markup to a GD&T markup stack. | On the GD&T Markup toolbar , click Stack Mode  . |

2. On the **GD&T Markup toolbar**, select **GD&T Annotation Editor** .
3. In the Tolerance page, choose one of the following formats from the **Tolerance** section:



- Equal Bilateral Tolerance 
- Unequal Bilateral Tolerance 
- Tolerance Limits 

Input fields in the Tolerance page are selected or cleared depending on the format you selected.

4. In the **Instances** section, click **X** to activate the text box, and type the number of tolerance instances this tolerance applies to.
5. In the **Leading Note** section, include both **Symbols** and text for your note.
6. (Optional) In the **Feature Size** section, click the diameter symbol and enter a value in the text box.
7. (Optional) In the **Upper Limit** section, type a value.
8. (Optional) In the **Lower Limit** section, type a value.
9. In the **Trailing Note** section, include both **Symbols** and text of your note.

10. (Optional) Use **Clear All** to clear all text.
11. To insert the markup, click **OK**.
12. In the Viewing window, depending on your insertion mode, click any point in the view or select a GD&T markup stack to add to.

Create a GD&T markup stack

1. If necessary, create the first GD&T markup of the stack.
2. On the **GD&T Markup** toolbar, click **Stack Mode** .
3. On the **GD&T Markup** toolbar, select **GD&T Annotation Editor** , and create the next markup of the stack.
4. Click **OK**.

The cursor changes icons, indicating the specific GD&T markup is ready to be stacked on another markup in the Viewing window.



5. In the Viewing window, click the target markup or markup stack.

The new GD&T markup symbol is stacked below the selected GD&T markup or markup stack. Both symbols will move together when dragged.

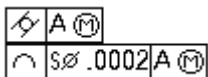

6. (Once the markups are stacked) In the Viewing window, right-click a GD&T markup, and select one of the following options:

| Use this option | To do this |
|-----------------------|---|
| Bring to Front | Move the selected markup to the front of the other markups. |
| Send to Back | Move the selected markup behind the other markups. |

| Use this option | To do this |
|-------------------|--|
| Move Up | Move the selected markup higher on the stack. |
| Move Down | Move the selected markup lower on the stack. |
| Unstack | Remove the markup from the stack. |
| Edit | Bring up the GD&T Annotation Editor dialog box. |
| Delete | Delete the markup. |
| Properties | Open the GD&T Markup Properties dialog box. |

Note:

The gap between a datum feature symbol that is stacked to another feature symbol is used to draw the backwards arrowhead base. Use this area to attach the other markup symbol.

Edit GD&T markups

1. In the Viewing window, right-click a GD&T markup, and choose **Edit**.

The markup appears in the **GD&T Annotation Editor** dialog box.

2. Edit the markup and click **OK**.

Change GD&T markup preferences and properties

You can change appearance preferences that apply to all new GD&T markups. You can also modify the appearance properties of an existing GD&T markup.

1. On the **GD&T Markup** toolbar, click **Preferences** .
2. In the **GD&T Markup Default Preferences** dialog box, set the preferences for edge, fill, or font.
3. (Optional) To modify the appearance of an existing GD&T markup, right-click the markup and select **Properties**.

Use the **GD&T Markup Properties** dialog box to modify existing markup properties, for example **Edge**, **Fill**, and **Font**.

If you place centerpoint, midpoint, intersection, or freehand **point markers** on vector or raster images, you can use the markers to make vector measurements.

When you use 2D measurement tools you can:

- **Measure** angles, radials, or distances.
- **Calibrate** measurements to define the distance between two points in a 2D image.
- Specify **measurement preferences**.

Tip:

To save measurement results as a 2D markup, use **Persist Measurements**. You can choose **Persist Measurements** from the 2D measurement toolbar or from the **2D measurement Preferences** dialog box.



By default, measurement results are not saved.

Calibrate the 2D measurement scale

1. On the **2D Measurement** toolbar, click **Enable Measurement** .
2. In the **Assembly** view, select a layer.

Note:

If more than one markup layer exists, you can calibrate each layer separately.

3. On the **2D Measurement** toolbar, click **Calibrate Vector**  or **Calibrate Raster** .
4. Click two points on your image.
 - For **Vector** measurements, click two points on the image.
 - For **Raster** measurements, click any two points.
5. In the **Calibrate Distance** dialog box, in the **Value** section, type a value to set the length of the distance for your image.
6. In the **Units** section, select a unit of measurement.

In the **Units** section, select **None** from the list to display values only. The unit of measurement (for example, millimeter) is not displayed in the Viewing window.

Measurements are displayed in the **Calibrate Distance** dialog box and are calculated based on the new calibration.

Note:

You do not need to use the same unit of measurement in your **preferences** that you use to calibrate the measurement device. You can calibrate your device in one unit of measurement and measure it in another.





Example:

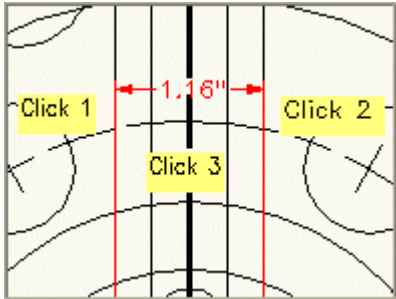

Assume you calibrate vector measurements in inches. Subsequently, you change units to feet, using **Preferences**. All entities that you previously measured in inches change to units in feet.

Measure 2D objects

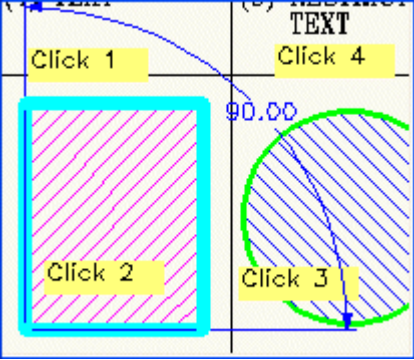
1. On the **2D Measurement** toolbar, click **Enable Measurement** .
2. Select a measurement type (vector or raster) on the **2D Measurement** toolbar, and then select one of the following options:

| To measure | Do this |
|--|--|
| Vector Linear  (measure the distance between points and vectors on your image) | <ol style="list-style-type: none"> a. Click a point in the image to set one endpoint. b. Click a second point on the image to set the other endpoint. c. Click to place the measurement label. <div style="text-align: center;">  </div> <div style="border: 1px solid black; padding: 5px; margin-top: 10px;"> <p>Note:</p> <p>You can create complex linear measurements by using a combination</p> </div> |

| To measure | Do this |
|--|--|
| | <div style="border: 1px solid black; padding: 5px;"> of 2D Markup point markers and 2D measurement tools. </div> |
| Vector Radial  (measure the radius of an arc using points and vectors on your image) | <ol style="list-style-type: none"> Click a point in the image to place one endpoint in the arc. Click two additional points to define the arc. Click to place the measurement label. <div style="border: 1px solid black; padding: 5px; margin-top: 10px;"> <p>Note:</p> <p>Some vector circles are approximations and the resulting vector measurements may be imprecise.</p> </div> |
| Vector 3 Pt Angular  (measure the angle between points and vectors on your image) | <ol style="list-style-type: none"> Click a point in the image to place the endpoint of one side. Click another point to place the vertex of the angle. Click a point to place the endpoint of the second side. Click the angle to place the measurement label. <div style="text-align: center; margin-top: 20px;">  </div> |
| Vector 4 Pt Angular  (measure the angle between two non-intersecting lines using points and vectors on your image) | <ol style="list-style-type: none"> Choose your first line in one of these ways: <ul style="list-style-type: none"> Click a point in the image to place the first endpoint of one line and |

| To measure | Do this |
|--|--|
| | <p>click another point to place the second endpoint of the line.</p> <ul style="list-style-type: none"> • Click a line. <p>b. Choose your second line in one of these ways:</p> <ul style="list-style-type: none"> • Click a point to place the first endpoint of the second line, and click on another point to place the second endpoint of the second line. • Click a second line. <p>c. Click the angle to place the measurement label.</p> <div style="border: 1px solid black; padding: 5px; margin-top: 10px;"> <p>Note: You cannot use this measurement tool with two parallel lines.</p> </div> |
| <p>Raster Linear  (measure a distance using screen pixels)</p> | <p>a. Click anywhere in the image to place one measurement point.</p> <p>b. Click another place in the image to place the second point.</p> <p>c. Click to place the measurement label.</p> |
| <p>Raster Radial  (measure the radius of an arc using screen pixels)</p> | <p>a. Click anywhere in the image to place one endpoint of the arc to measure.</p> <p>b. Click two additional points, in order, to define the arc.</p> <p>c. Click to place the measurement label.</p> |
| <p>Raster 3 Pt Angular  (measure an angle using screen pixels)</p> | <p>a. Click anywhere in the image to place the endpoint of one side.</p> <p>b. Click to place the vertex.</p> <p>c. Click to place the endpoint of the second side.</p> |

| To measure | Do this |
|--|---|
| | <p>d. Click the angle to place the measurement label.</p> <div data-bbox="873 331 1451 533" style="border: 1px solid black; padding: 5px;"> <p>Tip: To measure the obtuse angle rather than the acute angle, move the cursor inside the region opposite the acute angle.</p> </div> |
| <p>Raster 4 Pt Angular  (measure the angle between two non-intersecting lines using screen pixels)</p> | <p>a. Click anywhere in the image to place the endpoint of one line.</p> <p>b. Click to place the second endpoint of the line.</p> <p>c. Click to place the first endpoint of the second side.</p> <p>d. Click to place the second endpoint of the second line.</p> <p>e. Click the angle to place the measurement label.</p> <div data-bbox="873 1108 1451 1272" style="border: 1px solid black; padding: 5px;"> <p>Note: You cannot use this measurement tool with two parallel lines.</p> </div> |

Tip:

To save measurement results as a 2D markup, choose **Persist Measurements** on the 2D measurement toolbar or from the **2D measurement Preferences** dialog box.

By default, measurement results are not saved.

Create complex linear measurements

1. On the **2D Markup** toolbar, click **Enable Markup** .
2. To set two or more measurement markers, on the **2D Markup** toolbar, click two or more of the following.

Each marker is set in different ways. For details, review [Understanding 2D markers](#).

- **Freehand Marker** 

- **Intersection Marker** 

- **Midpoint Marker** 

- **Centerpoint Marker** 

3. On the **2D Measurement** toolbar, click **Vector Linear** .

4. Using the vector linear cursor, complete the measurements between the markers.

You can move the measurement information to the best location in the image.

Note:

You can use a combination of 2D Markup and 2D Measurement options to create complex linear measurements. Creating complex linear measurements involves establishing points or **markers** between the elements that you want to measure.

Understanding vector and raster measurement differences

Vector and raster images are composed of pixels. Vector graphics are based upon calculations so when you scale the graphic, vector lines are recalculated.

Raster images are drawn with individually points (pixels), which are then placed and arranged on a rectangular grid. When you view a raster image at increased magnification, the lines appear thicker.

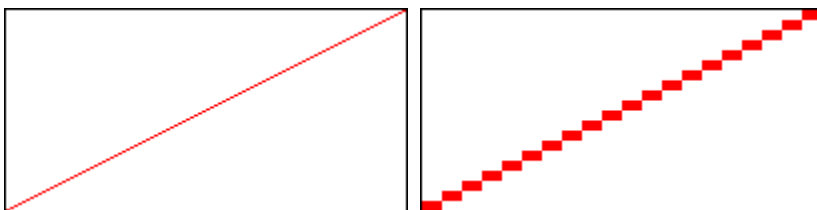

Close-up of a line
in a vector image

Close-up of a line
in a raster image

Measuring vector and raster images

You measure raster images with raster measurement tools only. But, you can measure vector images with vector or raster measurement tools. Vector measurements are generally more precise than

raster measurements, however, because vector images are approximations of model geometry, vector measurements may still be imprecise.

Example:

A vector image created from a cross section of a tessellated cylinder can appear to be a circle. Because the model of the cylinder is tessellated (made from triangles) the cross section is not a true circle, but an approximation of a circle created with short vectors.

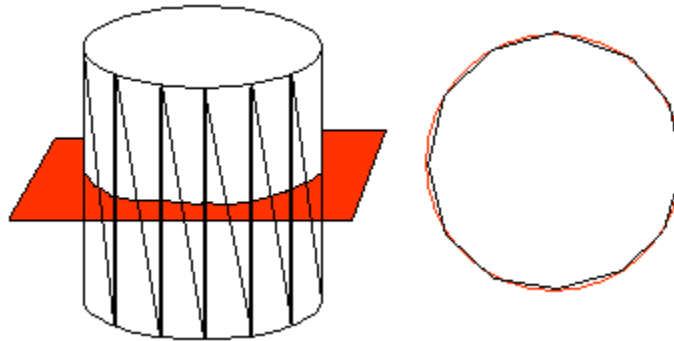

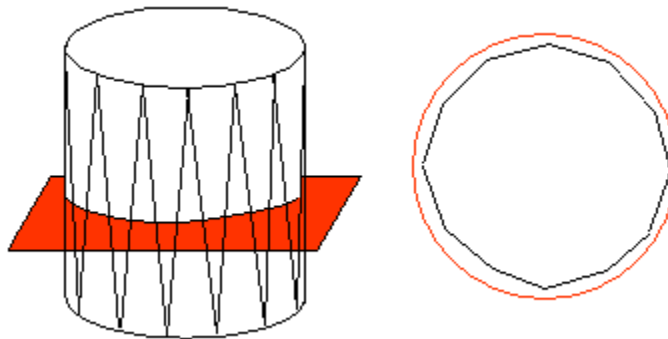

If one side of each of the triangles that makes up the tessellation lies exactly on the cylinder, as in the image above, a horizontal cross section plane cuts those edges and produces points that lie on a circle. When you measure these points with vector radial measurement, the measurement is precise, and produces the radius of the cylinder.

If none of the sides is on the true cylinder, the points of the vectors that make up the cross section do not lie on a circle. When you measure these points with a vector radial measurement, the measurement is not precise, and it does not produce the radius of the cylinder.



Configure preferences for measuring 2D objects

1. On the **2D Measurement** toolbar, choose **Enable Measurement** , and click **Preferences** .
2. In the **Preferences** dialog box, configure any of the following preferences:

| On this page | Use this option | To do this |
|--------------------|--|--|
| Measurement | Units | Specify measurement units (from millimeters to yards). Choose None to display values only. Symbols of measurement units are not displayed in the Viewing window. |
| | Precision | Specify the number of decimal places the measurement shows. |
| | Measurement color | Specify a measurement display color. |
| | Persist measurements | Maintain all measurements. Save measurement results as a 2D markup layer. |
| | Do not persist measurements | Maintain a display of the latest measurement on the base file. The measurement results are not save when you close the file. |
| Text | Font name | Select the font name for displaying measurements. <div style="border: 1px solid black; padding: 5px; margin-top: 10px;"> <p>Note: Available font styles may vary depending on which fonts are installed.</p> </div> |
| | Font style | Select the font style for displaying measurements. |
| | Font size | Select the font size for displaying measurements. |
| | Text Path | Not available at this time. |
| | Color | Not available at this time. |
| | Underline | Not available at this time. |
| | Strikeout | Not available at this time. |
| | Window size | Scale your text relative to the window size. |
| Layer size | Scale your text relative to the size of the base file or markup layer. | |

Measurements are displayed with the units, precision, and color you specified.

Note:

You use 2D measurement preferences to modify measurement characteristics such as configuring the level of measurement precision, the type of measurement units, and the color of

measurement output text and symbols. You can also persist measurements and modify standard text features, such as font size and font color.

9. Comparing 2D layers

Overview of comparing 2D layers

Use 2D comparisons to display commonalities or differences between two images. The two images could be the initial version of a document and a revision. When you open the first image, it appears in both the Viewing window and in the **Assembly** view. When you insert the second image, it is displayed as a layer.

If you then perform a 2D comparison, the results appear on a new layer. You can control and manipulate this layer to help view the results.

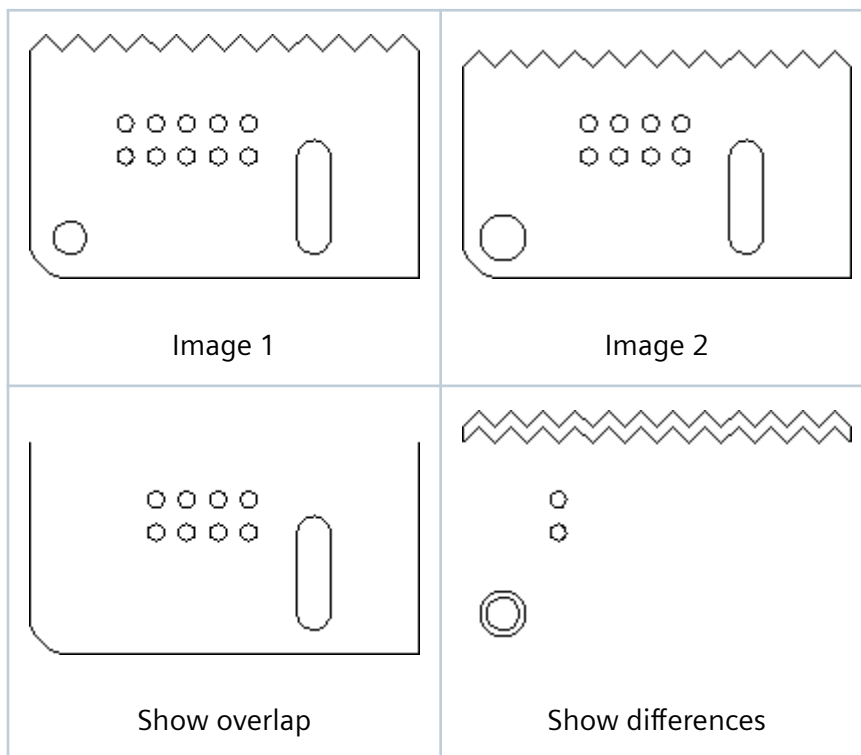

Note:

2D compare features are not supported in conference sessions.

Configure preferences for comparing 2D layers







1. On the **2D Compare** toolbar, click **Compare Preferences** .
2. In the **Compare Preferences** dialog box, choose any of the following:

| Use this option | To do this |
|-------------------------|---|
| First Layer | Specify the color for the first comparison layer. |
| Second Layer | Specify the color for the second comparison layer. |
| Show overlap | Display common elements from both comparison layers. |
| Show differences | Display elements that are unique to each of the layers. |

Tip:

You can also use **Toggle Layer Definition**  on the **2D Compare** toolbar to set either **Show overlap** or **Show differences**.

Create 2D comparison layers

1. Open the first image file you want to compare.
2. Insert the second file.
3. On the **2D Compare** toolbar, click **Compare Layers** .
4. In the **Compare Layer List Dialog** dialog box, verify or change the order of the first or second file. For multipaged files, you can also set the desired page number.
5. On the **2D Compare** toolbar, click the following:
 - a. **Display 1st Layer** 
 - b. **Display 2nd Layer** 
 - c. **Display Compare Layer** 
 - d. **Display All** 
 - e. **Toggle Layer Definition** 
 - f. **Clear Compare** 

Note:

- You can use comparison features to find the similarities or differences between two files. By default, the first layer is displayed in red and the second layer is displayed in green. Common elements are displayed in black.
- For multipage files, you can select specific pages to compare and create a new comparison layer for each page. To help with paging operations, use the 2D Multipage toolbar.

Example:

This example shows a 2D comparison where all layers are displayed. By default, the first layer is displayed in red, while the second layer is displayed in green. Parts that overlap and are displayed in both layers are shown in black.

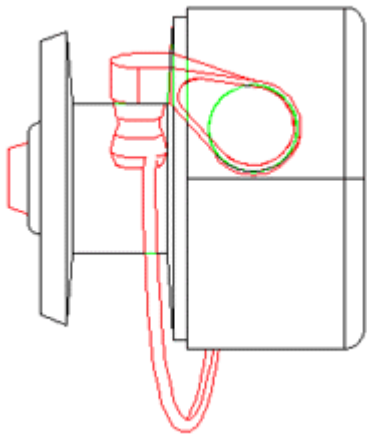

10. Adjusting 2D layers

Overview of adjusting 2D layers

When you open a 2D image file and then insert additional images, the base and inserted images appear in the Viewing window. You can use 2D adjust options to rotate, scale, and translate inserted images.

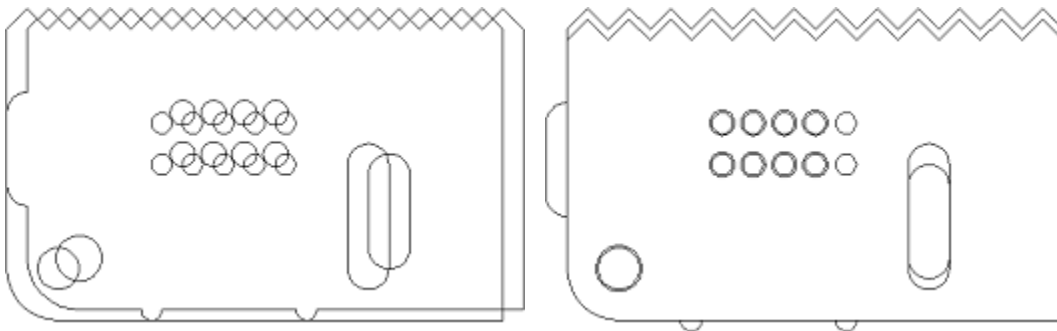

You can use 2D adjust options to do the following:

- Dynamically scale, rotate, and translate images on one markup layer independently of those on other layers.
- Translate an image on one markup layer by aligning a point on the image with a point on an image on different layer.
- Scale, rotate, and translate an image on one markup layer by aligning two points on the image with two points on an image on different layer.
- Reset the images on the adjusted layer.

Note:





- When working with multipage image files, adjustments made to inserted images are lost when you switch to a different page. If you capture adjustments in a snapshot before you switch pages, you can apply the snapshot to restore the adjustments.
- You can only align two files of the same file format.
- 2D adjust features are not supported in conference sessions.

Align 2D vector and raster points

1. **Add** a layer.

The inserted layer appears in the Viewing window along with the original 2D image.



2. On the **2D Adjust** toolbar, click **Enable Adjust** .
3. Choose a vector or raster option.

| To | Do this |
|--|--|
| Align a point on a markup layer with a point on another vector layer. <div style="border: 1px solid black; padding: 5px; margin-top: 10px;"> <p>Note: Vector alignment requires lines or arcs on both the markup layers.</p> </div> | Do one of the following: <ul style="list-style-type: none"> • On the 2D Adjust toolbar, click Align Vector One Point . • In the Viewing window, right-click and choose Vector Alignment → One Point. |
| Align two points on a vector markup layer with two points on another vector layer. <div style="border: 1px solid black; padding: 5px; margin-top: 10px;"> <p>Note: Vector alignment requires lines or arcs on both the markup layers.</p> </div> | Do one of the following: <ul style="list-style-type: none"> • On the 2D Adjust toolbar, click Align Vector Two Point . • In the Viewing window, right-click and choose Vector Alignment → Two Point. |
| Align a point on a raster markup layer with a point on another raster layer. | Do one of the following: <ul style="list-style-type: none"> • On the 2D Adjust toolbar, click Align Raster One Point . • In the Viewing window, right-click and choose Raster Alignment → One Point. |
| Align two points on a raster markup layer with two points on another raster layer. | Do one of the following: <ul style="list-style-type: none"> • On the 2D Adjust toolbar, click Align Raster Two Point . • In the Viewing window, right-click and point to Raster Alignment → Two Point. |

4. In the **Select Adjustment Layers** dialog box, from the **Fixed Layer** list, select the markup layer to remain stationary.
5. From the **Layer to Move** list, select the markup layer to align with the fixed layer.

6. The movable layer cursor appears and you can choose the points to align.





| If you chose this option | Take this action |
|--|---|
| <p>Align Vector One Point - or - Vector Alignment → One Point</p> | <p>a. Select a point near the end of the line or arc on the movable markup layer.</p> <p>A movable arrow appears and the cursor changes to a fixed layer cursor. </p> <p>b. Select a second point near the end of the line or arc on the fixed markup layer.</p> <div style="border: 1px solid black; padding: 5px; margin-top: 10px;"> <p>Note:</p> <p>If you select an unrecognized vector point, an outline shape with handle boxes appears on the image. To create the adjustment point, select one of the handle boxes.</p> </div> |
| <p>Align Vector Two Points - or - Vector Alignment → Two Point</p> | <p>a. Select a point near the end of a line or arc on the movable markup layer.</p> <p>A movable arrow appears and the cursor changes to a fixed layer cursor. </p> <p>b. Select a second point near the end of a line or arc on the fixed markup layer.</p> <p>c. Repeat each step.</p> |
| <p>Align Raster One Point - or - Raster Alignment → One Point</p> | <p>a. Select a point on the movable markup layer.</p> <p>A movable arrow appears and the cursor changes to a fixed layer cursor. </p> <p>b. Select a point on the fixed markup layer.</p> |
| <p>Align Raster Two Point - or -</p> | <p>a. Select a point on the movable markup layer.</p> |

| If you chose this option | Take this action |
|-----------------------------------|---|
| Raster Alignment→Two Point | <p>A movable arrow appears and the cursor changes to a fixed layer cursor. .</p> <p>b. Select a point on the fixed markup layer.</p> <p>c. Repeat each step.</p> <div style="border: 1px solid black; padding: 5px; margin-top: 10px;"> <p>Note:</p> <p>When you repeat this procedure for a second set of points, the end result is a 2D image that has been moved and scaled. The scaling is determined by how far apart the two points were originally.</p> </div> |

Move, zoom, and rotate 2D layers

1. **Add** a markup layer.
2. In the **Assembly** view, choose a layer.
3. On the **2D Adjust** toolbar, click **Enable Adjust** .
4. Choose any of the following options:

| To | Do this |
|---------------------------|---|
| Translate (pan) the layer | Do one of the following: <ul style="list-style-type: none"> • On the 2D Adjust toolbar, click Translate . • From inside the Viewing window, right-click and choose Translate. |
| Scale (zoom) the layer | Do one of the following: <ul style="list-style-type: none"> • On the 2D Adjust toolbar, click Scale . • From inside the Viewing window, right-click and choose Scale. |
| Rotate the layer | Do one of the following: <ul style="list-style-type: none"> • On the 2D Adjust toolbar, click Rotate . |

| To | Do this |
|----|---|
| | <ul style="list-style-type: none"> From inside the Viewing window, right-click and choose Rotate. |

5. In the Viewing window, drag the cursor to move the layer.

The layers resize as necessary so that all visible layers fit into the Viewing window.

6. To return a layer to its original position, select the layer to reset.

7. On the **2D Adjust** toolbar, click **Reset** .

-or-

From inside the Viewing window, right-click and choose **Reset**.

One of the following occurs:

| If you do this | This happens |
|---|---|
| Insert or create the selected layer in the current work session | All adjustments to the layer are cleared and the layer returns to its original position. |
| Open the selected layer by opening a session (VF) or PVL file | <p>All adjustments made to the opened sessions file are cleared and the layer returns to the saved sessions file position.</p> <div style="border: 1px solid black; padding: 10px;"> <p>Note:</p> <p>Click Reset again to clear all the adjustments made to the selected layer, including adjustments from the saved session.</p> <p>The layer returns to its original position.</p> <p>If you click Reset a third time, you return the selected layer back to the saved session position. In other words, clicking Reset switches the layer between a <i>clear</i> and an <i>as-loaded</i> state.</p> </div> |

11. Working with PDF documents

Accessing PDF documents using different operating systems

Your operating system determines how you view, markup, and create PDF documents as 2D file types.

- With Teamcenter lifecycle visualization using Windows, you open PDF documents directly into Lifecycle Visualization.
- With Teamcenter, you create a PDF as an **Image** dataset, and then open it in Teamcenter lifecycle visualization or send it to Lifecycle Viewer.

Note:

- To enable .pdf file viewing in Base, you must select 3D File Support from the list of Base features during installation.
- Installing a supported Adobe Acrobat suite is no longer required. Also, the Adobe Acrobat plug-in is no longer required or included with Teamcenter installations.

Viewing PDF documents with attached JT files

PDF documents may have attached JT files. When you open a PDF document, the PDF file opens in the 2D Viewing window, and each JT file opens in a separate 3D Viewing window.

Note:

In Adobe Acrobat Reader, you can see attached files by clicking the **Attachments** tab.

PDF documents may contain links such as to model views, PMI, and snapshots. To navigate the links, on the **2D Viewing** toolbar, click **Browse** . When you click a link, the target appears in the active 3D Viewing window; however, it must already be open. For example, when you click the link to a model view, the model view appears in the 3D Viewing window if the JT file with the model view is open.

Note:

Your operating system determines how you view, markup, and create PDF documents as 2D file types.

Display contents of PDF sticky notes

You can display the contents of PDF sticky note annotations and copy the contents to the clipboard.

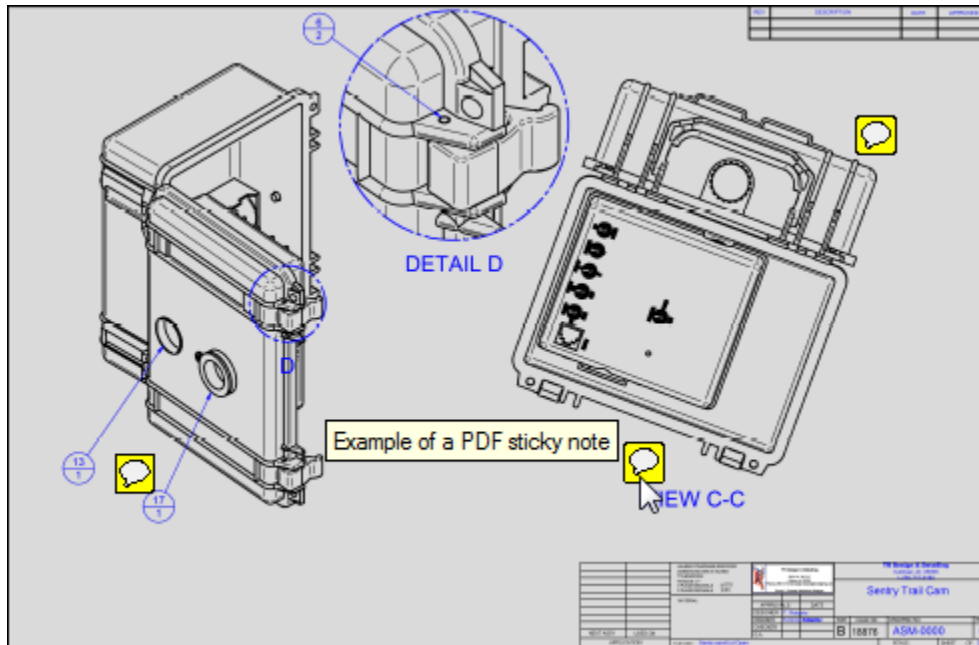

1. Open a PDF document containing sticky notes.
2. On the **2D Viewing** toolbar, click **Browse** .
3. Move the mouse pointer over a PDF note to display the contents.
4. (Optional) While the note is displayed, double-click to copy the contents to the Windows clipboard.

Searching PDF documents in Windows

About searching PDF documents

Use PDF text searching to quickly highlight strings found in PDF documents. You can search PDF documents for a single letter or an entire phrase. To help organize and process text searches, you use a standard search dialog to enter the text string. The dialog box supports finding the next and previous selections. And the number of instances of the text string is also displayed.

If the text string exists, the application highlights the string using the default feedback color. The highlight color is controlled by setting the feedback color in the **2D View Preference** dialog box.

Since PDF documents can be complex and text may be difficult to identify, a marker helps by pointing to the text string.

If the text string was not found, a message is displayed.

Note:

- PDF text searches are only supported on Windows systems.
- PDF text search is not available when the **Panning and Zooming Resampling PDF 2D loader preference** is not selected.
- PDF text search only applies to the PDF document base layer, and does not include markup layers or inserted documents.

Change the text highlight color when searching PDF documents

1. Right-click the PDF that is opened in the Viewing window and select **Preferences**.
2. In the **View Preferences** dialog box, from the **Feedback Color** list, choose the color you want for the highlight color.

The selected feedback color is changed for both the pointer as well as the text string.

Note:

When you click anywhere on the PDF document, the pointer disappears. When multiple matches are found and you navigate to the **Previous** or **Next** instance of the text string, the pointer reappears.

Find text strings in PDF documents

1. Open the PDF document in the Viewing window.
2. On the **2D Viewing** toolbar, click **Search** .
3. In the **Search Dialog** box that appears, enter the text string in **Text**.

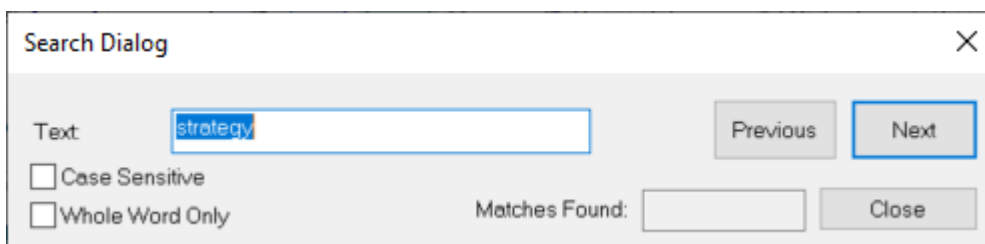

You can optionally set **Case Sensitive** and **Whole Word Only** searches.

Instances of the text string are displayed in **Matches Found**.

Tip:

You can also open the **Search Dialog** box by entering an **s** when the cursor is anywhere in the PDF document.